



# INSTALLATION AND OPERATION MANUAL

## Free-Standing EPA Certified Wood-Burning Stoves

Save These Instructions  
For Future Reference

P/N 900901-00, REV. D, 02/2026



Striker™ S160GL Series

## Striker™ Wood Stoves Models S160TGL (Traditional Door) S160AGL (Arched Door)



Report # 14-186

A French manual is available upon request. Order P/N 900901-01.



Ce manuel d'installation est disponible en francais, simplement en faire la demande. Numéro de la pièce 900901-01.

This appliance must be properly installed and operated in order to prevent the possibility of a house fire. Please read this entire installation and operation manual before installing and using your wood stove. Failure to follow these instructions could result in property damage, bodily injury or even death. Contact your local building or fire officials to obtain a permit and information on any installation requirements and inspection requirements in your area.

**NATIONAL FIREPLACE INSTITUTE**  
  
**CERTIFIED**  
[www.nficertified.org](http://www.nficertified.org)

We recommend that our woodburning hearth products be installed and serviced by professionals who are certified in the U.S. by the National Fireplace Institute® (NFI) as NFI Woodburning Specialists or who are certified in Canada by Wood Energy Technical Training (WETT).

  
 Wood Energy  
 Technical Training  
[www.wettinc.com](http://www.wettinc.com)

|   |   |
|---|---|
|  | <b>⚠ WARNING</b>  |
|  | <ul style="list-style-type: none"> <li>• <b>Hot! Do not touch! The glass and surfaces of this appliance will be hot during operation and will retain heat for a while after shutting off the appliance. Severe burns may result.</b></li> <li>• <b>Carefully supervise children in the same room as appliance.</b></li> </ul> |

## CONGRATULATIONS!

When you purchased your new wood stove, you joined the ranks of thousands of individuals whose answer to their home heating needs reflects their concern for aesthetics, efficiency and our environment. We extend our continued support to help you achieve the maximum benefit and enjoyment available from your new wood stove.

Thank you for selecting a Innovative Hearth Products (IHP) wood stove as the answer to your home supplemental heating needs.

## TABLE OF CONTENTS

|   |    |  |       |
|---|----|--|-------|
| Using This Manual .....                   | 2  | Manufactured (mobile) Home Installations .....   | 10    |
| Important Safety Information.....         | 3  | Chimney - Wall Pass-Through Requirements .....   | 11    |
| Testing Information.....                  | 4  | Leg and Heatshield Installation .....            | 12    |
| Draft Requirements.....                   | 4  | Outside Air Kit Installation.....                | 12    |
| Selecting the Proper Venting System.....  | 4  | Stove Installation .....                         | 13    |
| Negative Pressure Warning .....           | 5  | Pedestal Installation .....                      | 14    |
| Creosote.....                             | 5  | Post Installation Checks.....                    | 15    |
| Disposal of Ashes .....                   | 5  | Brick Installation .....                         | 15-16 |
| Fuel .....                                | 6  | Operating Hints .....                            | 17    |
| Paint Curing .....                        | 6  | Starting and Maintaining a Fire .....            | 17    |
| Burn-In Period .....                      | 6  | Blower Operation (optional kit) .....            | 18    |
| Clearances to Combustibles.....           | 7  | Operating Techniques and Hints.....              | 19    |
| Floor Protection .....                    | 7  | Getting the Most Out of Your Stove .....         | 19    |
| Reduced Clearances.....                   | 7  | Maximizing Your Stove's Overall Efficiency ..... | 19    |
| Alcove Clearances .....                   | 7  | Achieving Clean, Long Burns .....                | 19    |
| Chimney and Connector.....                | 7  | Maintenance.....                                 | 20-21 |
| Components Required for Installation..... | 7  | Troubleshooting .....                            | 22    |
| Installation Clearances .....             | 8  | Do's and Don'ts.....                             | 23    |
| Typical Installation Figures.....         | 9  | Smoke Detector Recommended.....                  | 23    |
| Chimney Installation .....                | 10 | Carbon Monoxide Monitor Recommended .....        | 23    |
|   |    | Replacement Parts List .....                     | 24-28 |
|   |    | Accessories.....                                 | 29    |
|   |    | Safety / Listing Label.....                      | 30    |
|   |    | Warranty .....                                   | 31    |
|   |    | Product Reference Information .....              | 32    |

### USING THIS MANUAL

Please read and carefully follow all of the instructions found in this manual. Please pay special attention to the safety instructions provided in this manual.

**PRODUCT IS SUBJECT TO CHANGE WITHOUT NOTICE**

## **IMPORTANT SAFETY AND WARNING INFORMATION**

### **READ THIS MANUAL IN ITS ENTIRETY AND UNDERSTAND THESE RULES TO FOLLOW FOR SAFETY.**

1. When this room heater is not properly installed, a house fire may result. To reduce the risk of fire, follow the installation instructions. Contact local building or fire officials about restrictions and installation inspection requirements in your area.
2. Wear gloves during installation to avoid injury from sharp edges on the stove and/or its parts.
3. This unit is designed and engineered to burn only dry, well-seasoned **wood**. Burning wet wood will greatly reduce the Stove's efficiency, produce excessive amounts of smoke and can cause dangerous chimney fires due to creosote build-up.
4. Before opening the door, the draft control must be fully open to avoid possible combustion flash (ignition of hot volatile gases as the door is opened).
5. Never use gasoline, gasoline-type lantern fuel, kerosene, charcoal lighter fluid, or similar liquids to start or 'freshen up' a fire in this heater. Keep all such liquids well away from the heater while it is in use. **DO NOT USE CHEMICALS OR FLUIDS TO START THE FIRE.**
6. While burning, fuel utilizes oxygen from the air in the room. Be sure to allow an adequate amount of fresh air into the room where the stove is burning.
7. The outside surface of the stove will be hot while burning properly and can set items like clothing and curtains on fire. Keep furnishings and other combustible materials away from the stove. Using the heat from the stove to dry wet clothing can be hazardous if clothes are placed too near the surface of the stove.
8. **HOT WHILE IN OPERATION. KEEP CHILDREN, CLOTHING FURNISHINGS AND COMBUSTIBLE MATERIAL A CONSIDERABLE DISTANCE AWAY. CONTACT MAY CAUSE SKIN BURNS.** Do not allow children to play near the stove without close supervision. Do not touch the stove while it is burning. Use extreme caution while the unit is in use. Surface temperatures become dangerously hot and can cause serious burns.
9. Do not allow anyone to operate the stove who is not familiar with the operating instructions.
10. Attempts to achieve heat output rates that exceed stove design specifications can result in permanent damage to the stove. Never leave your stove unattended on high burn rates. This may cause overfiring. Overfiring the stove may cause a house fire. If the stove glows, you are overfiring.
11. Keep a water hose or hand-operated fire extinguisher close for safety.
12. **Smoke Detectors** - Since there are always several potential sources of fire in any home, we recommend installing smoke detectors. If possible, install the smoke detector in a hallway adjacent to the room (to reduce the possibility of occasional false activation from the heat produced by the stove). If your local code requires a smoke detector be installed within the same room, you must follow the requirements of your local code. Check with your local building department for requirements in your area.
13. Inspect your chimney at least once a month during the burning season to check for soot and creosote accumulations. Any accumulations over 1/8" thick should be removed by a professional chimney sweep. Do not attempt to burn out heavy creosote accumulations with a hot fire. If large accumulations are occurring, review your burning procedures.
14. If a creosote fire should develop, the fire department should be called immediately and then attempts should be made to control the fire until assistance arrives. If a "runaway" fire should develop causing over-heating of the stove, the door and draft regulators should be closed immediately. The fire should die down once deprived of oxygen. After a severe chimney fire, the complete chimney system should be checked before further use.
15. **Do Not Use Grate Or Elevate Fire - Build Wood Fire Directly On Hearth** (firebrick). Do not use andirons or other methods of supporting the fuel.
16. Please read this entire manual before you install and use your new room heater. Failure to follow instructions may result in property damage, bodily injury, or even death.
17. Check all local building and safety codes before installation. The installation instructions and appropriate code requirements must be followed exactly and without compromise. In the absence of local codes the following standards and codes must be followed.
18. In the U.S.A, install in accordance with the National Fire Protection Association's Code, NFPA 211, Standards for Chimneys, Fireplaces, Vents and Solid-Fuel-Burning Appliances, or similar regulations, may apply to the installation of a Solid-Fuel-Burning appliance in your area. In Canada, the guideline is established by the CSA Standard, CAN/CSA-B365-M93, Installation Code for Solid-Fuel-Burning Appliances and Equipment.
19. **DO NOT CONNECT TO OR USE IN CONJUNCTION WITH ANY AIR DISTRIBUTION DUCTWORK UNLESS SPECIFICALLY APPROVED FOR SUCH INSTALLATIONS.**
20. **WARNING: BURNING IMPROPER FUEL (I.E. CHARCOAL) CAN RESULT IN CARBON MONOXIDE POISONING, WHICH MAY LEAD TO DEATH!**
21. **Carbon Monoxide Poisoning** - Early signs of carbon monoxide poisoning resemble the flu with headaches, dizziness, or nausea. If you have these signs, get fresh air at once! Have the heater inspected by a qualified service technician. Some people are more affected by carbon monoxide than others. These include pregnant women, people with heart or lung disease or anemia, those under the influence of alcohol, and those at high altitudes.
22. Failure to use manufacturer provided parts, variations in techniques and construction materials or practices other than those described in this manual may create a fire hazard and void the limited warranty.
23. Do not make any make-shift compromises during installation. Any modification or alteration may result in damage to the appliance or dwelling and will void the warranty, certification and listings of this unit.
24. These appliances are designed as supplemental heaters. Therefore, it is advisable to have an alternate heat source when installed in a dwelling.
25. These appliances shall not be Installed In a factory-built fireplace.

26. **Do Not Overfire – If Heater or Chimney Connector Glows, You Are Overfiring.**
27. **DO NOT CONNECT THIS UNIT TO A CHIMNEY FLUE SERVING ANOTHER APPLIANCE.**
28. **DO NOT BURN GARBAGE OR FLAMMABLE FLUIDS SUCH AS GASOLINE, NAPHTHA OR ENGINE OIL.**
29. **This wood heater has a manufacturer-set minimum low burn rate that must not be altered. It is against federal regulations to alter this setting or otherwise operate this wood heater in a manner inconsistent with operating instructions in this manual.**

**! WARNING**

**This product can expose you to chemicals including Carbon Black, which is known to the State of California to cause cancer, and Carbon Monoxide, which is known to the State of California to cause birth defects or other reproductive harm. For more information go to [www.P65Warnings.ca.gov](http://www.P65Warnings.ca.gov)**

### TESTING INFORMATION

This manual describes the installation and operation of these non-catalytic wood heaters. These heaters meet the U.S. Environmental Protection Agency's emissions limits, and are compliant with the 2020 EPA NSPS. These heaters have been developed, tested and constructed in accordance with the requirements of UL 1482-2022, CAN/ULC-S627:2023 and HUD standards and are listed by PFS TECO. These heaters have been approved for residential, mobile home and alcove installations.

| Model            | Emission Rate |           | EPA Test Range<br>BTU/hr | Efficiency** |     |
|------------------|---------------|-----------|--------------------------|--------------|-----|
|                  | Particulate   | CO *      |                          | HHV          | LHV |
| S160TGL, S160AGL | 1.7 g/hr      | 1.8 g/min | 12,800-39,400            | 72%          | 78% |

\* Average, subject to standard variations.  
 \*\* Low burn rate. CSA B415.1

### DRAFT REQUIREMENTS

Your wood stove is dependent upon a properly functioning chimney for optimum performance. It is a high efficiency appliance that loses much less heat up the chimney than older appliances and fireplaces. For this reason it is important to match the stove to the chimney. The chimney has two functions:

1. It draws combustion air into the appliance (without air, no fuel will burn) and
2. It exhausts combustion by-products. Your new appliance is what is known as a "natural draft" appliance.

The appliance depends solely on the natural draft of the chimney system to draw combustion air into the unit. Draft is the force that moves air from the appliance up into the chimney. The amount of draft in your chimney depends on the length of the chimney, local geography, nearby obstructions and other factors. Too much draft may cause excessive temperatures in the appliance (overfiring). Slow or inadequate draft equals poor combustion and possible smoking problems.

The following are some conditions that may contribute to poor chimney draft:

1. A chimney too large for your appliance.
2. A chimney with not enough height to produce adequate draft.
3. A chimney with excessive height (this may allow exhaust to cool too much before exiting, which will stall the rate the exhaust exits).
4. Offsets in the venting system are too restrictive (see *Chimney Guidelines*).

Inadequate draft will cause the appliance to leak smoke into the room through the stove and the chimney connector joints. Excessive draft may cause an uncontrollable burn or a glowing red stove or chimney part.

**Overfiring Damage** - If the heater or chimney connector glows, you are overfiring. Other symptoms may include: Cracking, warping or burning out of components, plated accessories may turn color, stove glass may develop a haze, which will not come off with cleaning.

Overfiring of a stove is a condition where excessive temperatures are reached, beyond the design capabilities of the appliance. The damage that occurs from overfiring is not covered under the manufacturer's limited warranty.

Also see *Troubleshooting* on **Page 22**.

### SELECTING THE PROPER VENTING SYSTEM

The appliance is merely one component of a larger system. The other equally important component is the venting system. This is necessary for achieving the required flow of combustion air to the fire chamber and for safely removing unwanted combustion byproducts from the appliance. If the venting system's design does not promote these ends, the system may not function properly. Poorly functioning venting systems may create performance problems as well as be a safety hazard. **A draft test should read greater than .04" W.C. (inches water column) and less than .08" W.C.** As per NFPA-211 standard (see paragraph below), the installer must take into account all variables within the installation and install the appliance in such a manner that satisfies the draft requirements of the appliance. See *Chimney Guidelines* below to assist you in selecting the proper venting system for your installation.

**American National Standards Institute ANSI/NFPA 211, Standard for Chimneys, Fireplaces, Vents, and Solid Fuel-Burning Appliances - See Draft Section:** A chimney or vent shall be so designed and constructed to develop a flow sufficient to completely remove all flue and vent gases to the outside atmosphere. The venting system shall satisfy the draft requirements of the connected appliance in accordance with the manufacturer's instructions.

#### **Chimney Guidelines:**

- This appliance requires approximately 12 feet minimum of "effective draw" provided by the venting system. As a rule of thumb, every 90 degree total direction change in the venting will result in a loss of approximately 5 feet of "effective draw." Example: If two 45 degree offsets are used, subtract 5 feet from the actual vertical vent height to determine your "effective draw." In this case if you had 14 feet of vertical vent, the effective draw would only be approximately 9 feet (14 ft. - 5 ft. = 9 ft.), therefore it may be necessary to add additional height to the venting system.
- Do not install an offset within the first two feet above the flue outlet on the appliance.
- In well insulated and weather tight homes, it may be difficult to establish a good draft up your chimney. The poor draft is caused by a shortage of air in the house. In this situation an Outside Air Kit may need to be installed (See *Negative Pressure Warning* on **Page 5** and *Outside Combustion Air* on **Page 12**).

## Chimney Height Requirements

The chimney must extend 3' (.92m) above the level of roof penetration and a minimum of 2' (.61m) higher than any roof surface within 10' (3m) (see below). Check with your local building officials for additional requirements for your area.

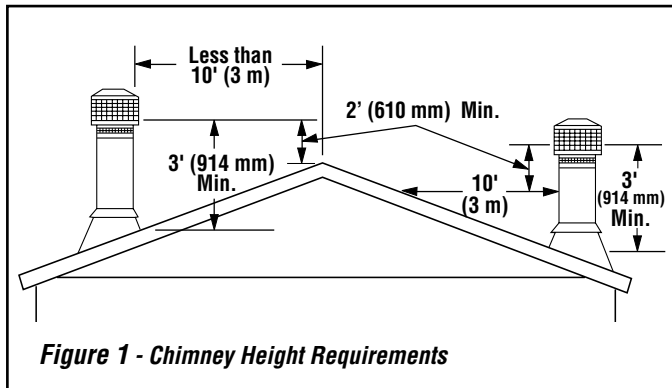

To pass inspection in nearly any jurisdiction, the chimney must meet both safety and exhaust flow requirements. The (3' by) 2' by 10' rule applies to both masonry and factory-built chimneys.

*\* Ref. USA - National Standard, NFPA 211-latest edition and Canada National Standard CSA B365-01-latest edition. Vents installed with a listed cap shall terminate in accordance with the terms of the cap's listings.*

## NEGATIVE PRESSURE WARNING

This appliance is not designed to be operated in a negative pressure. In very airtight homes with large kitchen exhaust fans, furnace cold air returns, fresh air exchange systems and any other air system in close proximity to the heating appliance may create a negative pressure in the same room as the heating appliance. This can create dangerous back drafting of the stove and chimney joints, drawing combustion by-products into the home. Be sure your home has adequate makeup air to eliminate negative pressures caused by the above-mentioned sources. Outside air connected to the appliance probably will not resolve such a problem as the appliance is not the source of negative pressure. IHP accepts no liability for damages resulting from negative pressures described here.

**Ventilation Requirements** - Provide adequate air for combustion. The fresh air requirements of this appliance must be met within the space where it will be installed. Ventilation is essential when using a Solid-Fuel-Burning heater. In well insulated and weather tight homes, it may be difficult to establish a good draft up the chimney (caused by a shortage of air in the home). The lack of air is caused by many common household appliances which exhaust air from the home (such as a furnace, heat pump, air conditioner, clothes dryer, exhaust fans, fireplaces, and other fuel burning appliances). Also, the combustion process of this heater uses oxygen from inside the dwelling. If the available fresh air delivery in the dwelling is insufficient to support the demands of these appliances, problems can result (i.e. excessive negative pressure can develop in the dwelling which will affect the rate at which this appliance can draft thus resulting in performance problems. To correct this problem it may help to open a window (preferably on the windward side of the house) or install an optional outside air kit.

## CREOSOTE

**Creosote Formation and Need for Removal** - When wood is burned slowly, it produces tar and other organic vapors, which combine with expelled moisture to form creosote. The creosote vapors condense in the relatively cool chimney flue of a slow-burning fire. As a result, creosote residue accumulates on the flue lining. When ignited, this creosote makes an extremely hot fire. The chimney and chimney connector should be inspected at least once monthly during the heating season to determine if a creosote build-up has occurred. If creosote has accumulated (1/8" [3 mm] or more), it should be removed to reduce the risk of a chimney fire.

**Establish a routine for the fuel, wood burner and firing technique. Check daily for creosote build-up until experience shows how often you need to clean to be safe. Be aware that the hotter the fire the less creosote is deposited, and weekly cleaning may be necessary in mild weather even though monthly cleaning may be enough in the coldest months. Contact your local municipal or provincial fire authority for information on how to handle a chimney fire. Have a clearly understood plan to handle a chimney fire.**

## DISPOSAL OF ASHES

**Whenever ashes get 3 to 4 inches deep in your firebox, and when the fire has burned down and cooled, remove excess ashes. Leave an ash bed approximately 1 inch deep on the firebox bottom to help maintain a hot charcoal bed.**

Ashes should be scooped out of a cool stove or fireplace insert with a small metal shovel. Ashes should be placed in a steel container with a tight fitting lid and moved outdoors immediately. Other waste shall not be placed in this container. The closed container of ashes should be placed on a non-combustible floor or on the ground, well away from all combustible materials, pending final disposal. If the ashes are disposed of by burial in soil or otherwise locally dispersed, they should be retained in the closed container until all the cinders have thoroughly cooled. Ashes can ignite up to 72 hours after removal from the appliance.

## FUEL

This appliance is designed to burn dry seasoned natural wood only (see *Page 23* for a list of prohibited fuels). Failure to burn proper fuels only will void the certification and the warranty of the appliance.

Dry, seasoned wood is that which has been cut, split and allowed to dry under a covered area where air is free to flow and circulate under and around the wood (not under a tarp or plastic). Make sure wood is not stacked directly on the ground, it may absorb moisture from the ground. It should be allowed to dry in these conditions for a minimum of six months, preferably one year or more. **IT MUST BE UNDERSTOOD THAT WOOD CANNOT BE LEFT IN ANY KIND OF WET OR DAMP AREA OR IT WILL NEVER BECOME COMPLETELY SEASONED.**

**Do Not store fuel within space heater installation clearances or within the space required for refueling and ash removal.**

### DO NOT OVERFIRE THIS HEATER

Attempts to achieve heat output rates that exceed heater design specifications can result in permanent damage to the heater.

### What does “Well-Seasoned” mean?

When a tree is cut down, the wood is green, full of sap and moisture. This moisture content can exceed 80%, which must be reduced to less than 20%. Wood properly seasoned is then capable of generating the heat the stove was designed to provide.

Green wood does not burn easily. Attempting to burn green wood often results in a lot of smoke and very little fire. Time is the most important factor in seasoning wood. Ideally the moisture content should be reduced to 11-20%. **NOTE: The use of a firewood moisture meter is recommended to ensure the firewood contains less than 20% moisture. Refer to moisture meter's owner's manual for proper operating instructions.**

### Seasoning Guide

Softwoods - 6 months to 18 months

Hardwoods - 12 months to 24 months

Logs that are 5" diameter across or larger should be split in half, three pieces if over 8 inches, and four pieces when over a foot across. If a tree has been dead for 2 - 4 years it still needs to be cut, split, and seasoned for 6 to 24 months depending on the wood.

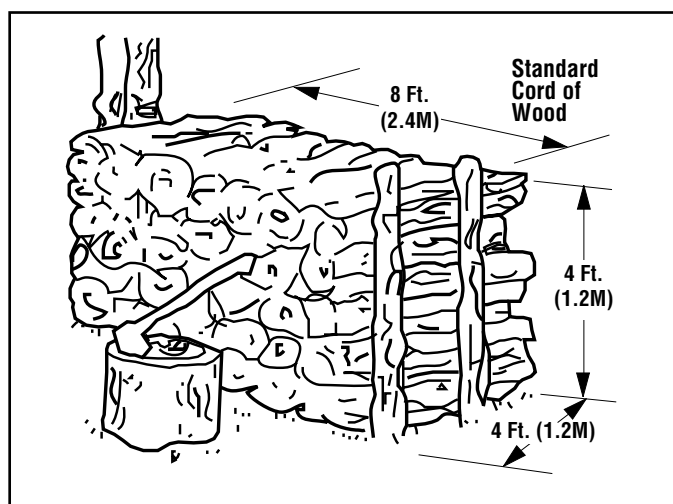

## PAINT CURING

If your appliance has plated accessories, be sure to clean plated surfaces with a household type glass cleaner and a very soft cloth to remove any fingerprints and residues prior to the first fire and before any fire if the plated surfaces have been handled or soiled. **Do not close the door tightly during the “Burn-In Period.” Also, open the door frequently (every 5-10 minutes) to keep the gasket from adhering to the curing paint.** Ventilate the house well during these first firings as the paint gives off carbon dioxide and unpleasant odors. It is recommended that persons sensitive to an imbalance in the indoor air quality avoid the appliance during the curing process.

Your new appliance is painted with a high temperature paint that cures during the first few firings. We recommend that you put your stove or fireplace insert through a regimen of three burns. The first two should last for 20 minutes each at 250 degrees (the appliance should be allowed to cool completely between each burn). The third should be a burn of at least 450 degrees F. for 45-60 minutes. The paint will become soft, gummy and emit non-toxic smoke during these burns. After the appliance cools down for the third time, the paint will harden. **DO NOT BUILD A LARGE ROARING FIRE UNTIL THIS CURING EFFECT IS COMPLETE OR YOU MAY DAMAGE THE FINISH OF YOUR STOVE.** Spray can touch-ups should be done only with a high temperature stove paint (cat. no. F5035), available from your dealer.

## BURN-IN PERIOD

Please be patient with the heat output of your appliance for the first few weeks. The steel will go through a curing process that eliminates moisture, which is deep in the steel and firebrick. This moisture will reduce initial heat output of your appliance and may make it difficult to start. **(DO NOT OVERFIRE THE STOVE DURING THIS PROCESS. IF THE STOVE OR CHIMNEY BECOMES RED, REDUCE THE AMOUNT OF AIR ENTERING THE STOVE IMMEDIATELY).**

## CLEARANCES TO COMBUSTIBLES

**WARNING: BE ABSOLUTELY SURE THE DISTANCE BETWEEN THE HEATER AND THE SURFACE OF ANY COMBUSTIBLE CONSTRUCTION IS NOT LESS THAN SHOWN IN THE FIGURES ON PAGE 8.**

### Floor Protection

**USA** - The floor in front and under the heater must be protected with noncombustible material. The covering must extend 16" in front of the door opening of the heater and 8" to either side of the door opening

**Canada** - The floor in front and under the heater must be protected with noncombustible material. The covering must extend 450 mm in front of the door opening of the heater and 200 mm to either side of the stove body and 200 mm to the rear or to the wall, whichever is smaller.

**USA and Canada** - A chimney connector / venting extends horizontally over the floor, protection must also cover the floor under the connector / venting and at least 2" (51 mm) to either side.

### Reduced Clearances

Clearances to combustible surfaces can be reduced with the use of listed double wall connector pipe. See the clearances with double wall pipe on the following page.

### Alcove Clearances

**Single Wall Pipe** - Minimum 48" (1219 mm) width, maximum 48" (1219 mm) depth. Minimum ceiling height is 84" (2134 mm).

**Double Wall Pipe** - Minimum 44" (1117 mm) width, maximum 48" (1219 mm) depth. Minimum ceiling height is 72" (1829 mm).

## Chimney and Connector

Minimum 6" diameter, minimum 24 MSG black steel connector pipe with UL103HT listed factory-built chimney suitable for use with solid fuels or masonry chimney. Horizontal connection not tested, refer to local building codes for installation. See installation instructions for details. Restrictions apply! Read instructions before installing.

Clearance dimensions are to 6" (152 mm) flue collar. If a single wall connector pipe with shield is used, a 1 inch air space is needed between pipe and shield. Shield attaches to rear of stove pipe and must run from stove top to ceiling. Pipe shield shall be UL listed.

Residential chimney systems must be from the same brands as listed for mobile homes but connector pipe may be double wall, single wall or single wall with shield as listed above.

This appliance may be vented into a code-approved masonry chimney with flue liner.

**WARNING: Chimney connector must be in good condition and kept clean. Do not install damaged parts.**

All of the stove connector pipe used must be of the same brand. The chimney that the stove pipe transitions into may be a different brand. Other than the transition of the stove pipe into the chimney, do Not mix different brand vent components. Install all vent components per vent manufacturer's instructions.

The chimney connector shall not pass through an attic or roof space, closet or similar concealed space, or a floor, or ceiling. Where passage through a wall, or partition of combustible construction is desired, the installation shall conform to CAN/CSA-B365, Installation Code for Solid-Fuel-Burning Appliances and Equipment.

There must be an effective vapor barrier at the location where the chimney or other component penetrates to the exterior of the structure. Follow the vent manufacturer's detailed instructions.

**IMPORTANT NOTE:** See *Draft Requirements* and *Selecting a Proper Venting System* on **Page 4** to assist you in choosing the proper venting system for your installation.

## Components Required For Installation

Legs AND Bottom Heat Shield or Pedestal Base.

**Use all required components specified for this appliance. Do not substitute.**

**WARNING: In the event that you remove the blower for any reason, make sure a cover plate (available from IHP) is installed before using the heater. Excessive rear wall temperatures will result if the stove is burned without the cover plate. NOTE: The cover plate is not necessary if a blower has never been installed because a knock-out will be in place to act as the cover.**

**INSTALLATION CLEARANCES - REFER TO FIGURES 2, 3 AND 4**

| PIPE                       | INSTALLATION                          | A                    | B (1)        | C                    | D (1)            | E†          | F (1,4)         | G (4)                    |
|----------------------------|---------------------------------------|----------------------|--------------|----------------------|------------------|-------------|-----------------|--------------------------|
| 6" Single Wall             | Residential or Alcove                 | USA-16"<br>CAN-483mm | 14"<br>356mm | USA-21"<br>CAN-610mm | 12-1/2"<br>318mm | 8"<br>200mm | 9-3/4"<br>248mm | USA-18"<br>CAN-533mm     |
| ② 6" Single w/ Pipe Shield | Residential or Alcove                 | USA-10"<br>CAN-330mm | 8"<br>200mm  | USA-18"<br>CAN-533mm | 9-1/2"<br>241mm  | 8"<br>200mm | 5-1/2"<br>140mm | USA-13-1/2"<br>CAN-419mm |
| 6" Double Wall             | Residential or Alcove or Mobile Home* | USA-10"<br>CAN-330mm | 8"<br>200mm  | USA-18"<br>CAN-533mm | 9-1/2"<br>241mm  | 8"<br>200mm | 5-1/2"<br>140mm | USA-13-1/2"<br>CAN-419mm |

| PIPE                    | INSTALLATION                          | H (2)                     | I (6)                     | J (2)                     | K                    | L (5)               | M             |
|-------------------------|---------------------------------------|---------------------------|---------------------------|---------------------------|----------------------|---------------------|---------------|
| Single Wall             | Residential or Alcove                 | USA-33-3/4"<br>CAN-1111mm | USA-47-3/4"<br>CAN-1340mm | USA-33-1/2"<br>CAN-1003mm | USA-16"<br>CAN-450mm | USA 0"<br>CAN-200mm | 84"<br>2134mm |
| ② Single w/ Pipe Shield | Residential or Alcove                 | USA-33-3/4"<br>CAN-1111mm | USA-41-3/4"<br>CAN-1188mm | USA-33-1/2"<br>CAN-1003mm | USA-16"<br>CAN-450mm | USA 0"<br>CAN-200mm | 84"<br>2134mm |
| Double Wall Air-Cooled  | Residential or Alcove or Mobile Home* | USA-33-3/4"<br>CAN-1111mm | USA-41-3/4"<br>CAN-1188mm | USA-33-1/2"<br>CAN-1003mm | USA-16"<br>CAN-450mm | USA 0"<br>CAN-200mm | 72"<br>1829mm |

| PIPE                    | INSTALLATION                          | N ①          | P ①          | T (6)                     |
|-------------------------|---------------------------------------|--------------|--------------|---------------------------|
| Single Wall             | Residential or Alcove                 | 30"<br>762mm | 36"<br>914mm | USA-58-1/2"<br>CAN-1645mm |
| ② Single w/ Pipe Shield | Residential or Alcove                 | 30"<br>762mm | 36"<br>914mm | USA-52"<br>CAN-1486mm     |
| Double Wall Air-Cooled  | Residential or Alcove or Mobile Home* | 30"<br>762mm | 36"<br>914mm | USA-52"<br>CAN-1486mm     |

† USA=8" (200mm) from door opening, Canada=8" (200mm) from sides and back of unit

① Dimensions to Stove Body  
② Clearances may only be reduced by means approved by the regulatory authority.

\* Mobile Home - USA only

**Figure 2** Top View-Parallel Installation

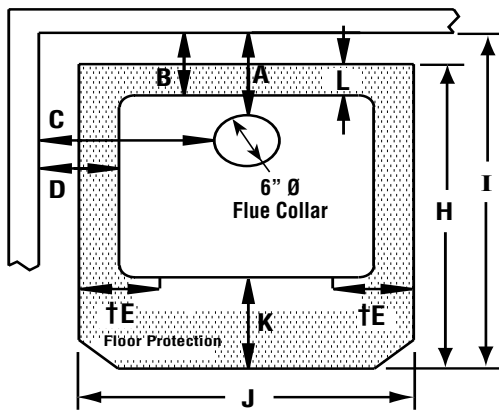

**Figure 3** Side View-Alcove & Parallel Installation

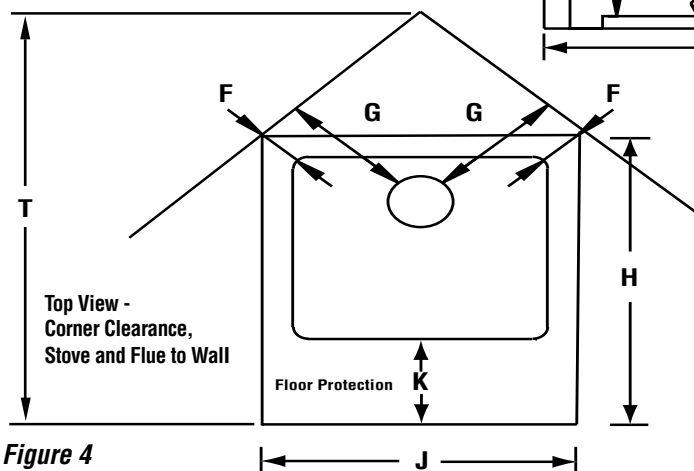
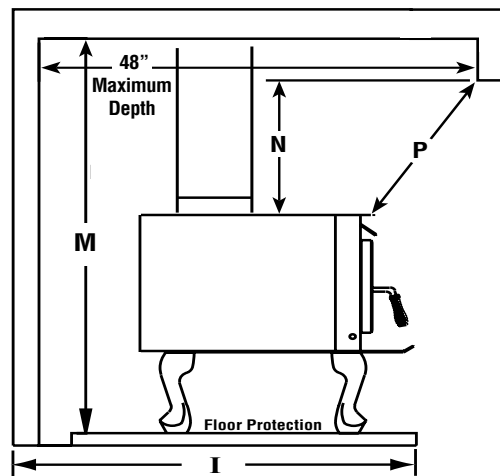

**Figure 4**

**Footnotes:**

- 1- These dimensions to the stove body are for reference only. Actual distances should be measured from the stove's flue collar.
- 2- Minimum noncombustible hearth pad dimensions.
- 3- Shield shall be attached to the rear of the stove pipe with a 1" air space and must run from the top of the stove to the ceiling.
- 4- Not applicable to alcove installations.
- 5- In corner applications, when installed at minimum back wall clearances, the required floor protection is dimensioned off the back plane of the stove, therefore the floor protection required off the back corners (at a 45 degree angle) only needs to extend to the wall. This situation will only occur in CANADA installations.
- 6- Reference dimension only, to assist in planning the installation. Clearances to connector pipe shall be measured from the flue collar of the stove.

NOTE: DIAGRAMS & ILLUSTRATIONS ARE NOT TO SCALE.

**Single Wall Pipe**  
Using 6" Diameter Single Wall Connector Pipe

**INSTALL VENTING SYSTEM PER VENT MANUFACTURERS INSTRUCTIONS!**

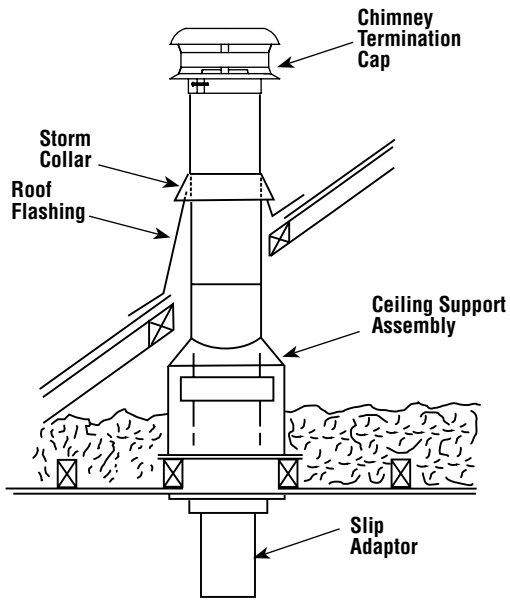

Single wall stove pipe must not pass through attics, closets, walls or ceilings. It is used to connect this appliance to a factory built or masonry chimney.

Fasten each stove pipe connection with at least 3 sheet metal screws.

6" x 24" 24-gage black steel or 26 gage blued steel single wall pipe

Fasten stove pipe to flue collar with 3 sheet metal screws.

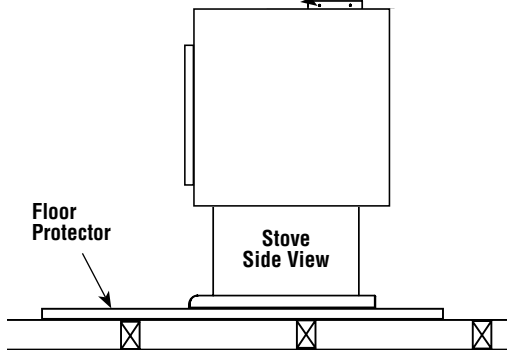

**Figure 5 - Typical Installation**

**STAINLESS STEEL LINER**  
Using 6" Diameter Rigid Stainless Steel Liner

**INSTALL VENTING SYSTEM PER VENT MANUFACTURERS INSTRUCTIONS!**

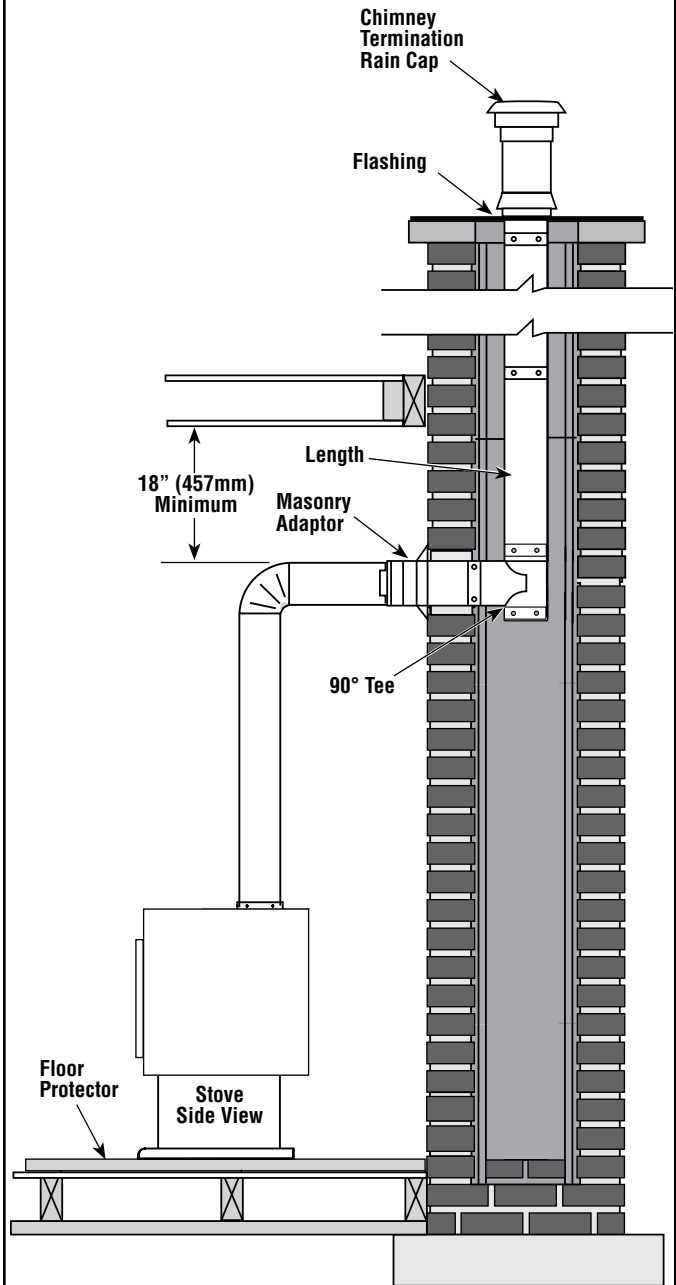

**Figure 6 - Connected to a Masonry Chimney**

**YOUR CHIMNEY INSTALLATION MUST COMPLY WITH LOCAL BUILDING AND FIRE CODES.**

## CHIMNEY INSTALLATION

- Install chimney as per manufacturer's instructions. Some brands of pipe may require removal of the spacer ring in the flue collar.
- All horizontal runs of pipe should be as short as possible and are required by NFPA No. 211 to have an upward pitch or rise in the same direction the smoke travels of no less than 1/4" to the linear foot. The connector pipe must meet minimum clearances in any direction to walls or other combustible materials. It must attach to a listed double wall metal chimney at least 6" in diameter or to a masonry chimney with a flue passage of at least 48 square inches.
- It is required that a chimney connector pipe not extend further than the inner wall of the flue when it is connected to a masonry chimney and that it either be cemented to the masonry or be installed without cement in a thimble connected to the masonry wall. When the connector is inserted into a thimble, the joint must be tight enough so that it will not be dislodged in normal use. Install connector at no less than the minimum clearances from the ceiling when using a 90-degree elbow to pass through combustible constructions.
- Chimney connector pipes should never pass through a floor, ceiling, fire wall, partition, or combustible construction of any type unless certain precautions are taken. The best method is to use a listed thimble and a listed chimney in accordance with the manufacturer's directions. NFPA No. 211 gives approved methods for passing a flue pipe through combustible constructions (see **Page 11**).

### Manufactured Home Installations (ref. **Figure 7**)

**This appliance is approved for installation into a manufactured (mobile) home in the USA ONLY!**

Installation should be in accordance with the **Mobile Home Construction and Safety Standard, Title 24 CFR, Part 3280 (in Canada CAN/CSA Z240 MH)**, or, when such a standard is not applicable, the **Standard for Mobile Home Installations, ANSI A225.1**.

All mobile home installations require an outside air kit (see **Page 29** for ordering information). The stove must be secured to the floor and grounded to the chassis of the mobile home.

**WARNING: DO NOT INSTALL IN SLEEPING ROOM OF A MOBILE HOME.**

**CAUTION: THE STRUCTURAL INTEGRITY OF THE MOBILE HOME FLOOR, WALL AND CEILING/ROOF MUST BE MAINTAINED.**

**Approved Chimney** - Your stove is approved for use with Class A, UL 103 HT (U.S.) / ULC-S629 (Canada) Listed Residential Type and Building Heating Appliance Chimney (HT chimney - 2100° Fahrenheit) and double wall connector pipe. Approved chimney brands are Security Chimneys™, Jakes Evans/GSW, Dura-vent, Metal Fab, Ameri-Tec, Metalbestos and Industrial Chimney (ICC).

Clearances to connector shall be measured from 6" flue collar. Restrictions apply! Read instructions before installing.

**YOUR CHIMNEY INSTALLATION MUST COMPLY WITH LOCAL BUILDING AND FIRE CODES.**

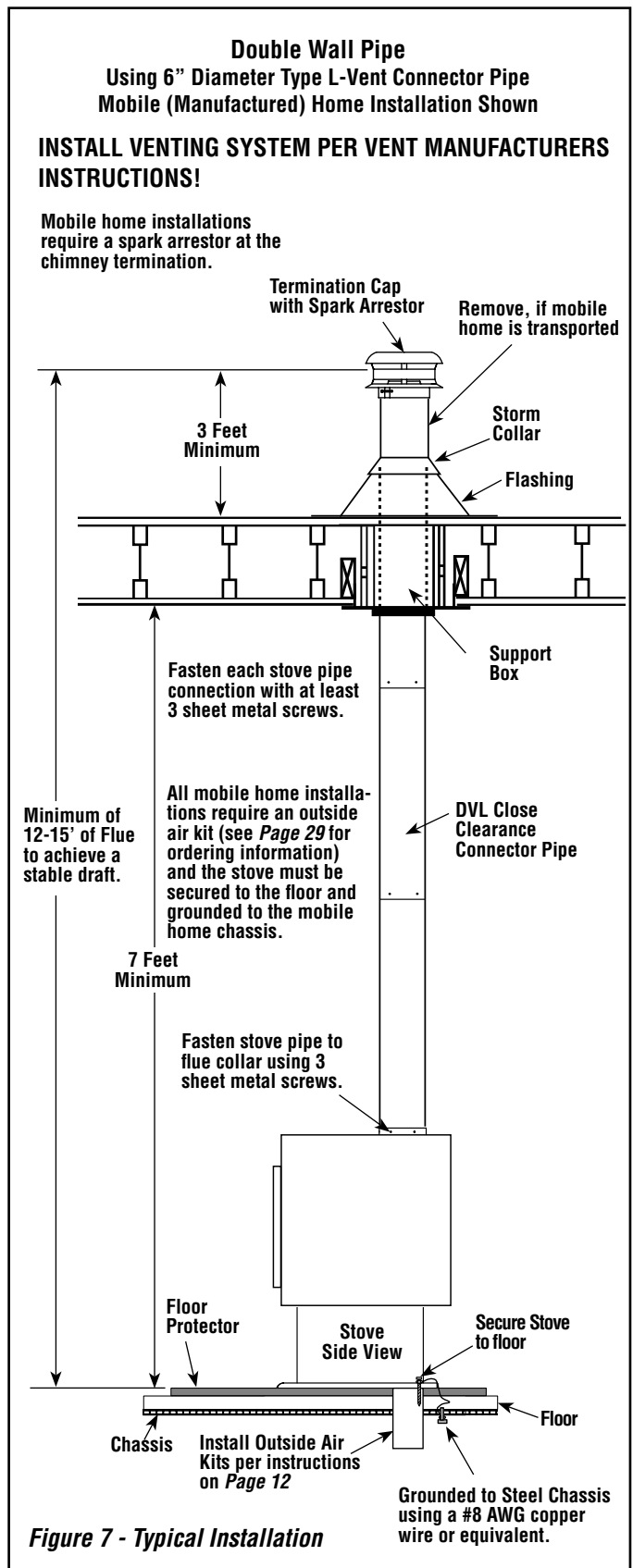

**Chimney Connector Systems and Clearances from Combustible Walls for Residential Heating Appliances (NFPA 211) Refer to Figure 8**

**System A.** Minimum 3.5 in. (90 mm) thick brick masonry wall framed into combustible wall with a minimum of 12 in. (305 mm) brick separation from clay liner to combustibles. Fireclay liner (ASTM C 315, Standard Specification for Clay Flue Linings, or equivalent), minimum 5/8 in. (16 mm) wall thickness, shall run from outer surface of brick wall to, but not beyond, the inner surface of chimney flue liner and shall be firmly cemented in place.

Clearance: 12 in. (305 mm)

**System B.** Solid-insulated, listed factory-built chimney length of the same inside diameter as the chimney connector and having 1 in. (25.4 mm) or more of insulation with a minimum 9 in. (229 mm) air space between the outer wall of the chimney length and combustibles.

The inner end of the chimney length shall be flush with the inside of the masonry chimney flue and shall be sealed to the flue and to the brick masonry penetration with non-water-soluble refractory cement. Supports shall be securely fastened to wall surfaces on all sides.

Fasteners between supports and the chimney length shall not penetrate the chimney liner.

Clearance: 9 in. (229 mm)

**System C.** Sheet steel chimney connector, minimum 24 gauge [0.024 in. (0.61 mm)] in thickness, with a ventilated thimble, minimum 24 gauge [0.024 in. (0.61 mm)] in thickness, having two 1 in. (25.4 mm) air channels, separated from combustibles by a minimum of 6 in. (152 mm) of glass fiber insulation. Opening shall be covered, and thimble supported with a sheet steel support, minimum 24 gauge [0.024 in. (0.61 mm)] in thickness.

Supports shall be securely fastened to wall surfaces on all sides and shall be sized to fit and hold chimney section. Fasteners used to secure chimney section shall not penetrate chimney flue liner.

Clearance: 6 in. (152 mm)

**System D.** Solid-insulated, listed factory-built chimney length with an inside diameter 2 in. (51 mm) larger than the chimney connector and having 1 in. (25.4 mm) or more of insulation, serving as a pass-through for a single wall sheet steel chimney connector of minimum 24 gauge [0.024 in. (0.61 mm)] thickness, with a minimum 2 in. (51 mm) air space between the outer wall of chimney section and combustibles. Minimum length of chimney section shall be 12 in. (305 mm). Chimney section concentric with and spaced 1 in. (25.4 mm) away from connector by means of sheet steel support plates on both ends of chimney section. Opening shall be covered, and chimney section supported on both sides with sheet steel supports of minimum 24 gauge [0.024 in. (0.61 mm)] thickness.

Supports shall be securely fastened to wall surfaces on all sides and shall be sized to fit and hold chimney section. Fasteners used to secure chimney section shall not penetrate chimney flue liner.

Clearance: 2 in. (51 mm)

**Additional requirements:**

1. Insulation material used as part of wall pass-through system shall be of noncombustible material and shall have a thermal conductivity of 1.0 Btu-in./hr-ft<sup>2</sup> - °F (4.88 kg-cal/hr-m<sup>2</sup> - °C) or less.
2. All clearances and thicknesses are minimums; larger clearances and thicknesses shall be permitted.
3. Any material used to close up an opening for the connector shall be of noncombustible material.
4. A connector to a masonry chimney, except for System B, shall extend in one continuous piece through the wall pass-through system and the chimney wall to the inner face of the flue liner, but not beyond.

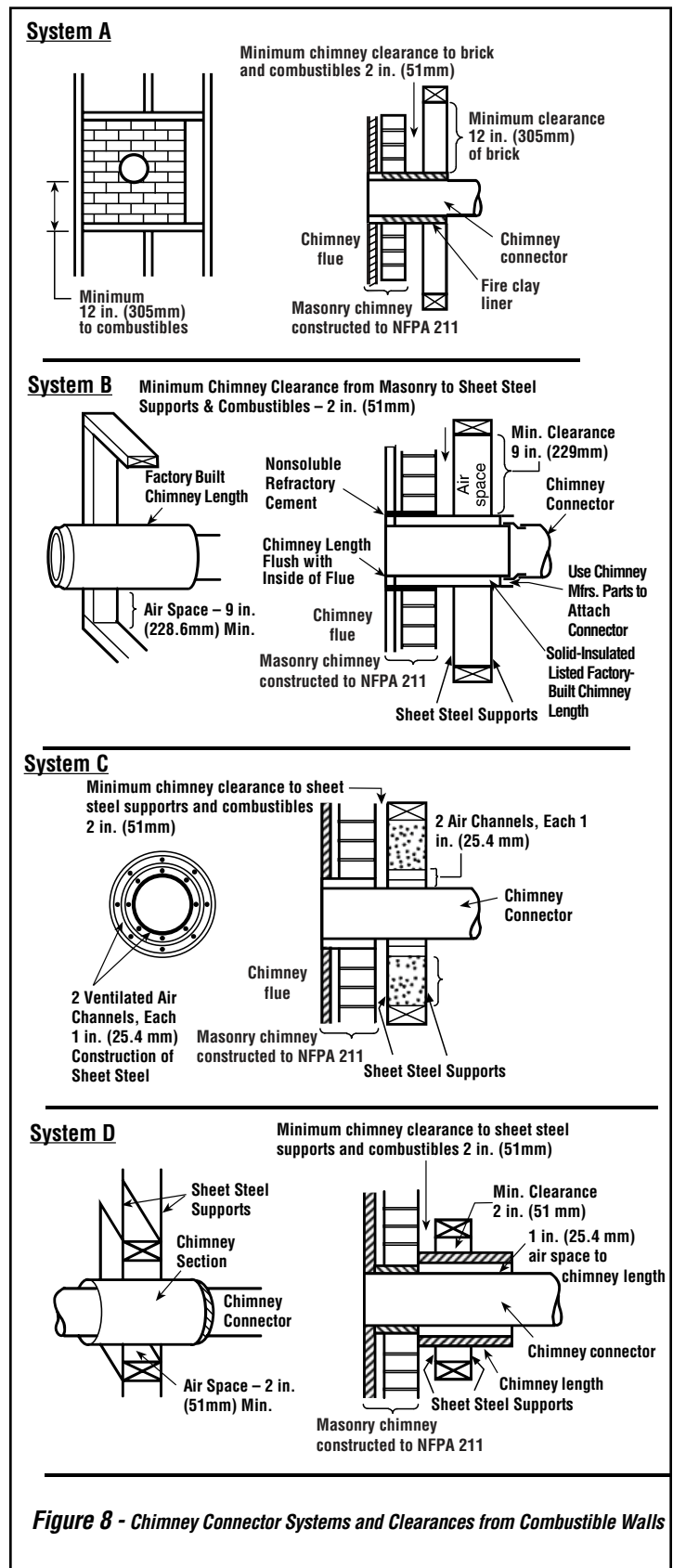

**Figure 8 - Chimney Connector Systems and Clearances from Combustible Walls**

## LEG AND HEATSHIELD INSTALLATION

**NOTE:** The threaded rods used to bolt the legs to the stove are packaged with the heatshield, as a heatshield is required when a stove is installed on legs.

### Residential and Mobile Homes

(Bolting down and grounding of stove are required only in mobile homes).

Open all cartons, if any and remove the contents upon receipt and check for any damaged or missing parts. If there is hidden damage, notify your freight company or IHP dealer immediately.

**CAUTION:** Wear gloves during installation in case of sharp edges on the stove.

### Leg Installation

1. Carefully place stove on its back. Be careful not to scratch the stove, use a piece of cardboard or carpet to protect the back of the stove.
2. Mount all four legs as shown in *Figure 9*.
3. First, screw the threaded rods into the holes at the four corners on the bottom of the stove. Screw the threaded rods into the firebox three full rotations or 3/16 to 1/4" (if the rear rods are screwed in too far they will lift the bricks off the bottom of the stove). Use a washer and nut to secure the leg. Be sure the legs are mounted squarely on the firebox bottom. Tighten nuts securely.
4. Use the two bolts and washers provided with the heatshield kit to mount the heatshield as shown in *Figure 10*.
5. Do not over tighten the heatshield mounting bolts as it may bend the heatshield.

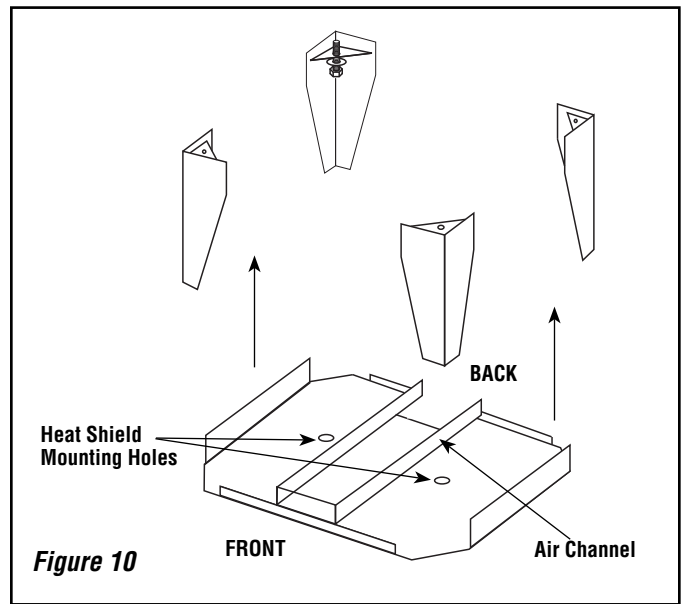
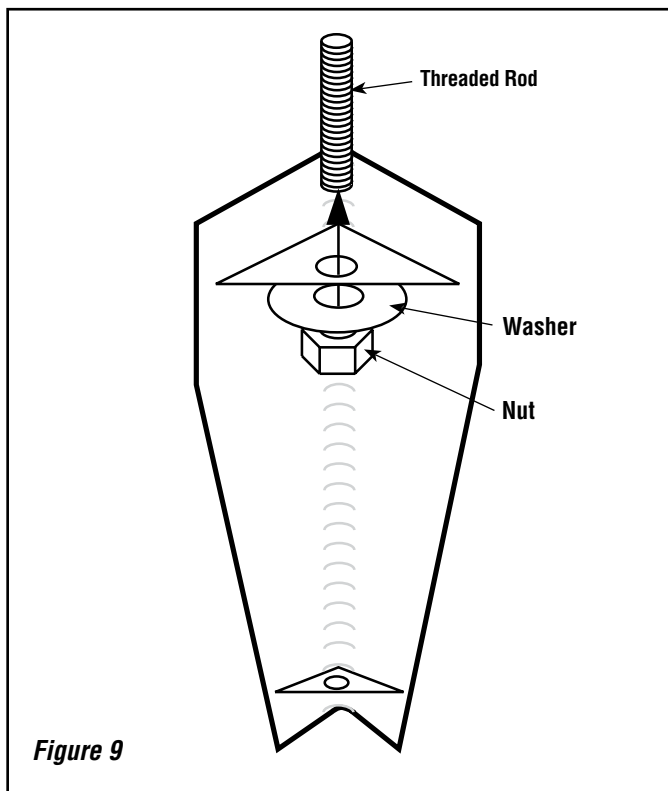

## OUTSIDE AIR KIT INSTALLATION

To install the "Outside Air Kit," position the clip so that the nut is directly above the hole punched in the back of the heatshield (See *Figure 11*). Install the outside air adapter box on the stove by sliding it into the air channel located between the bottom heatshield and the stove bottom until the oblong ring is approximately 1/4" from the rear edge of the lower heatshield. Make sure the ring is facing down. Thread the 1/4" bolt up through the nut in the clip until snug against the adapter box.

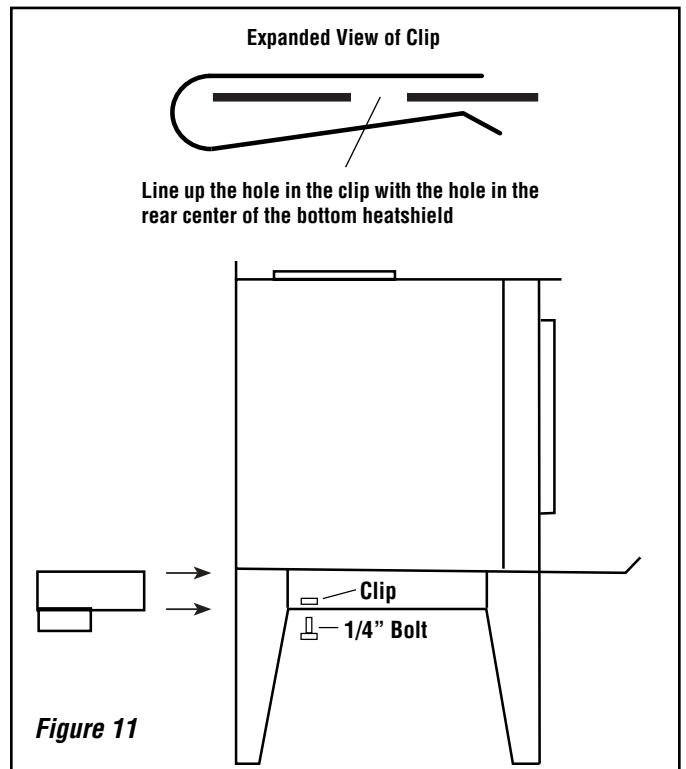

To locate the hole in the hearth for outside air, mark a 4" circle on the hearth. The circle's center should be 2-3/4" directly back from the center of the flue outlet and 5/8" to the left side.

## STOVE INSTALLATION

1. If not previously installed, install floor protection and move the heater into the desired location.
2. Position the stove on your floor protection in the exact location where it is to be located, making sure all minimum clearances are met.
3. If you are installing outside air on your stove, mark a 4" circle on the floor protection just below the oblong ring. When cut out, this hole will accommodate the flexible outside air tube.
4. If the stove is to be fastened to the floor, locate the hold down brackets inside the leg box and mark the floor protection below the holes in the brackets.
5. If you are installing outside air on your stove, remove the stove and cut the floor protection and the floor where the 4" air tube circle had been previously drawn. If the stove is to be fastened to the floor, drill 1/2" holes through the floor protection only, at the marks that were for fastening the stove to the floor if so desired. Slip the flexible outside air tube through the hole in the floor, leaving 1" of tube above the floor protector surface, using tape to hold it in place.
6. Place the stove on the floor protection so that the previously cut or drilled holes line up. Attach the stove to the floor with the lag bolts if so desired.
7. If you are installing outside air on your stove place the hose clamp over the flexible air tube and slide the tube up over the 4" ring on the outside air adaptor box and tighten the hose clamp. Push the outside air adaptor forward 1/4" until full contact is made with the lower heatshield. Tighten the 1/4" bolt until the adaptor box is held firmly in place. Use silicone sealant to create a seal between the flexible air tube and your floor protection.
8. If it is necessary to level, secure or ground your stove, use the holes in the bottom of the leg for those applications. To level the stove on Olympic cast legs, locate the front leg that is not touching the hearth pad. Insert the allen head screw through the slotted washer (supplied with the legs) and into the threaded hole in the bottom of the leg. See **Figure 12**. Push the slotted washer down until it touches the hearth pad and then tighten the screw into the leg. Should any other leg not be resting on the hearth pad, install a washer and screw in that leg as well.
9. Install baffle boards and baffle blanket as per instructions on **Pages 15 and 16**. It is highly recommended that the baffle be assembled before the chimney is installed so that the baffle blanket can be adjusted into place through the flue collar.
10. If installed into a mobile home, the stove shall be grounded to the mobile home chassis with a #8 AWG copper wire or equivalent.
11. For residential installations, install the first section of stove pipe with the crimped end going down inside the flue collar on the heater. Continue with your stove pipe, installing each section-crimped end down. Make the final connection to your chimney. Your dealer carries the necessary pipe and fittings to connect to the various listed factory-built chimneys. **YOUR CHIMNEY INSTALLATION MUST COMPLY WITH LOCAL BUILDING AND FIRE CODES.**
12. Be sure to fasten each stove pipe connection with at least 3 sheet metal screws.
13. Install chimney as per manufacturer's instructions. Some brands of pipe may require removal of the spacer ring in the flue collar.
14. All horizontal runs of pipe should be as short as possible and are required by NFPA No. 211 to have an upward pitch or rise in the same direction the smoke travels of no less than 1/4" to the linear foot. The connector pipe must meet minimum clearances in any direction to walls or other combustible materials. It must attach to a listed double wall metal chimney at least 6" in diameter or to a masonry chimney with a flue passage of at least 48 square inches.
15. It is required that a chimney connector pipe not extend further than the inner wall of the flue when it is connected to a masonry chimney and that it either be cemented to the masonry or be installed without cement in a thimble connected to the masonry wall. When the connector is inserted into a thimble, the joint must be tight enough so that it will not be dislodged in normal use. Install connector at no less than the minimum clearances from the ceiling when using a 90-degree elbow to pass through combustible constructions.
16. Chimney connector pipes should never pass through a floor, ceiling, fire wall, partition, or combustible construction of any type unless certain precautions are taken. The best method is to use a listed thimble and a listed chimney in accordance with the manufactures directions. NFPA No. 211 gives approved methods for passing a flue pipe through combustible constructions.

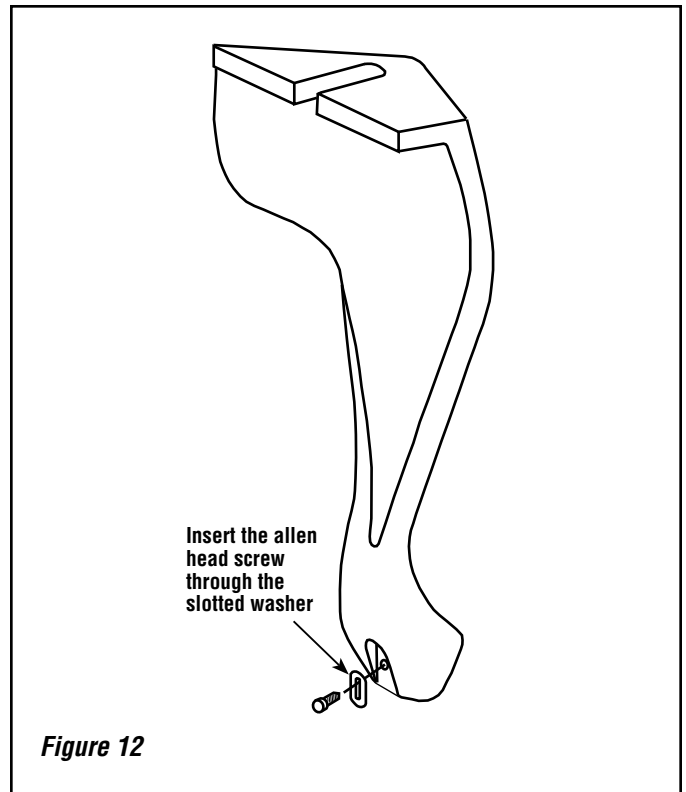

**Figure 12**

## PEDESTAL INSTALLATION

(For ash drawer pedestal see instructions included with pedestal)

### Residential and Mobile Homes

(Bolting down and grounding are required only in mobile homes)

#### **CAUTION: Wear gloves during installation in case of sharp edges on the stove.**

1. Remove the heater from the carton, if packaged, upon receipt and check for any damaged or missing parts.
2. Carefully put the stove on pedestal with the open end of the pedestal facing the rear. **DO NOT LEAVE THE STOVE UNATTENDED UNTIL IT IS BOLTED SECURELY TO THE PEDESTAL.**
3. Line up the holes in the brackets on the pedestal with the threaded holes in the bottom of the stove. Use the two 1/2" long bolts and 3/8" standard washers to bolt the stove to the pedestal. **Be sure to see that the stove is mounted squarely on the pedestal before tightening the two bolts securely.**
4. When installing a pedestal on this stove you **MUST** plug the four leg mounting bolt holes, located on the bottom of the stove in the four corners, with the bolts that were used to mount the shipping legs. **The two rear bolts should not be installed more than two full rotations to prevent lifting the bricks off the bottom of the stove. FAILURE TO INSTALL THESE FOUR BOLTS PROPERLY WILL RESULT IN REDUCED CONTROL OF THE STOVE'S COMBUSTION SYSTEM!**

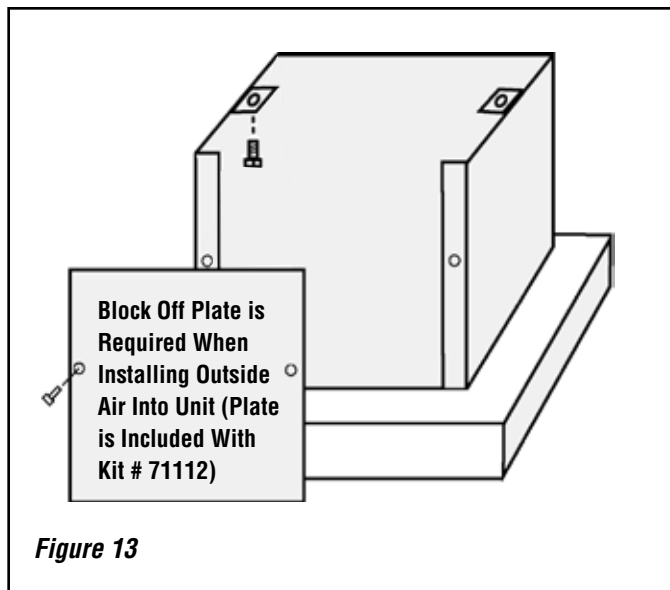

**Figure 13**

5. If required, install the Outside Air Kit (cat. no. 71112) as per the following instructions. To locate the hole in the hearth for outside air mark and cut a 4" (102 mm) hole in the hearth. The hole's center should be 3" (76 mm) directly forward from the center of the flue outlet or locate as per the instructions below.
6. Position the stove on your floor protection in the exact location where it is to be located, making sure all minimum clearances are met. Mark the floor protection where the pedestal will be located, then remove the stove.
7. Make four 1-1/2" (38 mm) cuts in one end of the corrugated tube and fold the flaps back. Cut a 4" (102 mm) hole through the floor protection and the floor and insert the corrugated tube into the hole. Cover it with the supplied screen and fasten it to the floor protector.
8. Locate the 11-1/2" x 14" (292 mm x 356 mm) metal plate and paint to match the stove if necessary. Position this piece so that the 14" (356 mm) dimension evenly overlaps the lips on the back of the pedestal (see drawing below). Attach this plate to the back of the pedestal with the self-tapping screws supplied.
9. If the stove is to be fastened to the floor, attach the stove with the supplied lag bolts, through the pedestal base on opposite sides, attaching them into the floor beneath the floor protection. Seal any irregularities with silicone sealer.
10. If installed in a mobile home, the heater shall be grounded to the chassis with a #8 AWG copper wire or equivalent.
11. Install bricks as per instructions on **Pages 15 and 16**. It is highly recommended that the baffle be assembled before the chimney is installed so that the baffle blanket can be adjusted into place from the flue outlet.
12. Install chimney as per manufacturer's instructions.

## POST INSTALLATION CHECKS

1. Check that all chimney pipe joints are securely fastened.
2. Check that the heater is securely fastened to the floor (if applicable).
3. Make sure the intake vent has clear access to outside air (if applicable).
4. Make sure the outside air vent has been sealed properly to keep rodents out (if applicable).
5. Be sure all roof flashings are watertight.
6. Be sure the stove is properly grounded (if applicable).

**FOR YOUR OWN PROTECTION AND INSURANCE PURPOSES, HAVE YOUR CHIMNEY AND CONNECTOR PIPE INSTALLATION INSPECTED BY YOUR LOCAL BUILDING CODE AUTHORITY OR FIRE MARSHAL BEFORE STARTING A FIRE IN YOUR STOVE. NOTIFY YOUR INSURANCE COMPANY.**

## BRICK INSTALLATION

**CAUTION: Wear gloves in case of sharp edges inside the stove.**

**NOTE:** Installation of the baffle boards and baffle blanket is easier when you can still access the flue outlet, (before connecting the flue vent). **Be sure the baffle blanket is placed flat on the baffle boards so as not to block exhaust flow to the flue.** Use a ruler or a piece of kindling to reach over the baffle blanket to be sure it is completely flat on top of the baffle boards.

Measure bricks before installing, as per list of dimensions on next page, to be sure the correct bricks are installed in the correct location.

1. Install bricks #1-18 in the numbered sequence shown in **Figure 14** on **Page 16**.
2. Next, you will install the rear baffle boards which are the smaller two of the four baffle boards. The boards will be installed with the 3-9/16" dimension from the front to the rear of the firebox. These boards will be placed on the top side of the rear baffle just to the rear of the middle secondary tube, you will push the baffle boards towards the rear of the firebox until they fall in place at the rear side of the middle secondary tube. You will place one board to the far left side of the firebox and one board to far right side of the firebox. Confirm that both boards are laying flat on the rear baffle and that they are not overlapping each other.

3. Next, you will install the baffle blanket. It will be installed with the 11" dimension from the front to rear of the firebox. Install by lifting it into place between the front and rear baffle. Place the blanket over the rear baffle and rear baffle boards that you have just installed. Next you will place the baffle blanket that is protruding beyond the front side rear baffle on the top side of the front baffle.
4. The final step of the baffle board & baffle blanket installation will be installing the front baffle boards. The front baffle boards will be the two remaining baffle boards which are the larger two baffle boards of the four baffle board kit. They will be installed with the 7-3/8" dimension from the front to rear of the firebox. Start by setting the back side of the board on the rear baffle making sure that it is placed far enough back to lift up and onto the front baffle. Next you will place the front edge of the front baffle boards on the top side of the front baffle and slide them towards the firebox front until it stops against the front baffle edge. You will do this with each front baffle board with one to the right side of the firebox and one to the left side of the firebox. Confirm that the baffle blanket is directly on top of the baffle boards and that it does not protrude beyond the front baffle or front baffle boards as shown in **Figure 15** (also see note on **Page 15**).

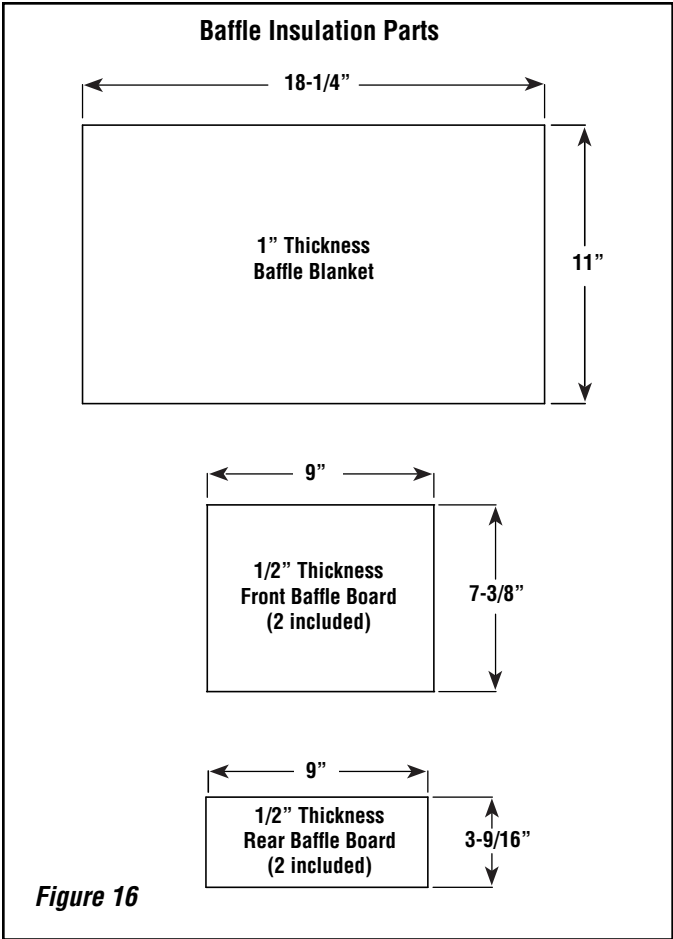
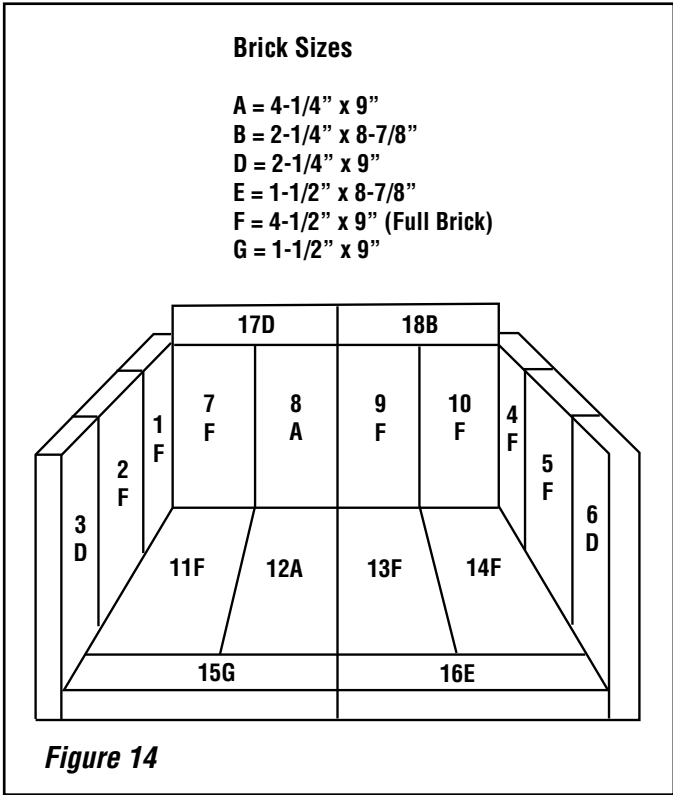
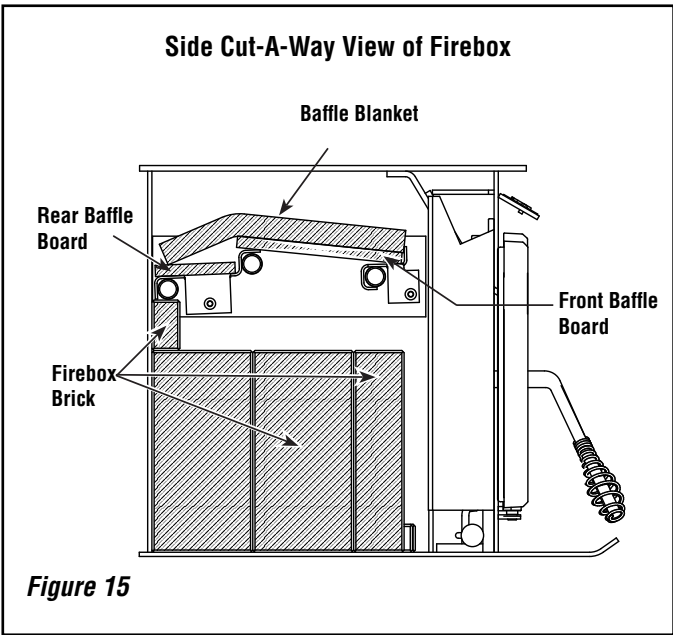

## OPERATING HINTS

1. Burn only dry, well-seasoned wood for maximum heat output. In some states it is illegal to burn wet wood or anything other than clean, dry wood products.
2. Your stove or fireplace insert is designed to operate with the door closed! Operate only with the door shut tightly at all times except when loading wood and possibly on start up to establish a draft. Never leave the unit unattended while the front door is slightly opened.
3. **DO NOT** hit or move the baffle board while loading wood. Occasionally check the baffle. Make sure the baffle blanket is always flush with the front of the baffle boards. Loading oversized logs may dislodge the baffle boards.
4. **CAUTION: THE DRAFT CONTROL MUST BE FULLY OPEN BEFORE OPENING THE DOOR TO AVOID POSSIBLE COMBUSTION FLASH!!** (Ignition of hot volatile gases as the door is opened).
5. Feeding excessive amounts of fuel to the appliance should be avoided. It is important to supply it with sufficient draft and fuel to maintain a moderately hot fire. If, during overnight burns, heavy creosote deposits develop inside your stove and on the door, the draft is set too low - review your burning habits!

## WARNING

Be careful not to abuse door assembly by striking or slamming it. If the door assembly or glass is broken or damaged, they must be replaced with factory original parts before heater can be safely operated. Use only components provided by the manufacturer as replacement parts.

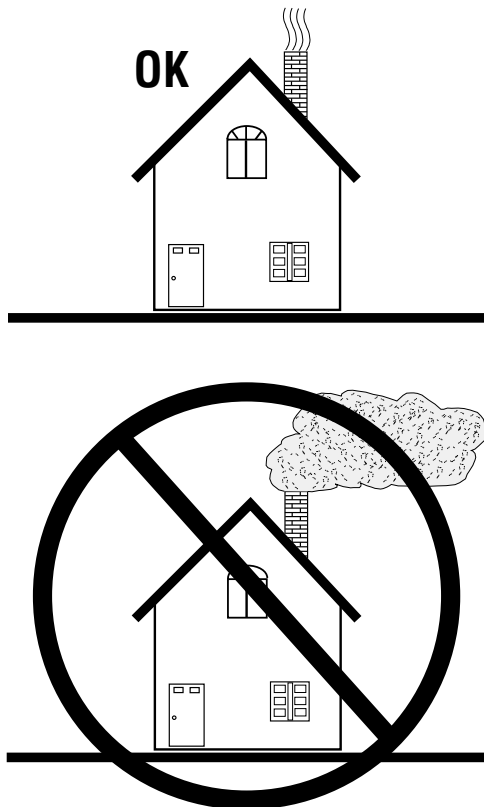

Figure 17

## STARTING AND MAINTAINING A FIRE

**Be sure to clean plated accessories with a household type cleaner and a very soft cloth to remove any fingerprints and residues prior to the first fire.**

1. **NEVER USE FLAMMABLE LIQUIDS TO START OR REKINDLE A SOLID FUEL FIRE!!**
2. Fully open the primary draft control by pulling the 1" plastic knob out on the left side (lower front corner) until it stops (away from the stove). This control determines the amount of air entering the stove. Pushing it toward the stove reduces the burn rate in the firebox. For your convenience, the rod on this control is marked with four grooves to assist you in obtaining repeatable burn rates.
3. Place a small amount of crumpled paper in front of the firebox and cover it with a few pieces of kindling.
4. Light the paper and allow sufficient time for the kindling to become fully engulfed in flames. You will now close the wood units front door. (Your wood units front door may or may not need to be left slightly open during this start up process, this depends on the appliance model and the amount of draft present. Do not leave the unit unattended while the front door is slightly open) Once kindling is burning well, larger pieces of wood may be added, then the door should be fully closed if there was the need to keep it slightly open during start up.

**DO NOT LEAVE THE STOVE UNATTENDED WHILE THE FRONT DOOR IS SLIGHTLY OPEN.**

**CAUTION: Do Not alter the adjustment range of the draft control for increased firing for any reason.**

**Operate only with fuel door and ash drawer closed. Maintain all seals in good condition. Do not operate with broken glass.**

**Do Not build the fire too close to the glass.**

**Do not operate the appliance with the door open or ajar other than possibly during start up to create a draft (Do not leave the unit unattended while the front door is slightly open during start up). Operating the appliance with the door open other than in initial start up if needed will produce extreme temperatures within the appliance. Damage caused from over-firing is not covered under the manufacturers limited warranty.**

5. When operating any wood burning appliance, it is important to become familiar with how the damper control affects heat output and the overall temperature of the appliance. A stove thermometer can be a helpful tool to help ensure you are not over-firing your appliance and it will also ensure you are burning fuel at a rate that is most efficient. Place a stove thermometer on the top of the appliance. Monitor the temperature every 15 minutes or so until you become more familiar with your appliance. Close the damper all the way down if you begin to reach 600 degrees, as this is a sign that you are operating your appliance at too high a temperature.
6. For best results, use smaller pieces of wood and light the fire from the top of the kindling pile to get the appliance temperature very high before loading larger wood for sustained burns. If necessary, crack the door to allow ignition of the fuel charge. **Do not leave the unit unattended while the front door is slightly open.** Now you can add larger pieces of wood and after several minutes of high burn, set the left control for the desired heat output. Check the exhaust in about 15 to 20 minutes. Large amounts of smoke indicate an improper burn setting (either too high or too low). Adjust and recheck in 5 to 10 minutes.

## BLOWER OPERATION

### Blower Operation

The blower can be operated manually or automatically (blower will turn on when the stove is hot and turn off when the stove is cool).

The rocker switch on the control panel allows you to select between manual operation or automatic operation as follows (see **Figure 19**):

— **MANUAL OPERATION:** Turn rocker switch to the “MANUAL” position and adjust rheostat knob to the desired speed. The blower will have to be manually turned “OFF” by rotating the rheostat knob clockwise until it clicks.

— **AUTO OPERATION:** Turn rocker switch to the “AUTO” position and the rheostat to the ON position (rotate rheostat knob counterclockwise until it clicks). When the stove or insert warms up, the blower will automatically turn on (adjust rheostat knob to the desired speed setting). When the stove or insert cools down, the blower will automatically turn off.

**Rheostat Operation** - The highest blower speed is obtained by turning the rheostat knob counterclockwise until it clicks “ON”, then rotate towards “HIGH” to increase blower speed. Rotate the knob clockwise for a lower speed. To turn off, continue to rotate the knob clockwise until it clicks “OFF.”

### Blower Operation Guidelines

While in auto operation mode, the blower will turn off and on based on the temperature of the appliance. Auto operation ensures there is sufficient heat build-up to warm the air being moved by the blower before the blower is turned on. Likewise, when the appliance cools off, the blower is turned off to prevent circulating cool air. Depending on the size and intensity of the fire it may be necessary to adjust the blower speed accordingly to ensure uninterrupted blower operation. For example a small fire may require a slower blower speed to keep the heat output by the blower consistent. If the blower is operated in manual mode, it may be necessary to adjust the blower speed as the fire begins to burn down and the appliance is no longer hot enough to effectively heat the air moved by the blower. If the air coming from the blower feels cool, one should either decrease the blower speed or stoke the fire to build up more heat.

**NOTE: Turn blower off before opening the door to load the fuel.**



Blower Speed Control Knob (rheostat)

Manual / Auto Rocker Switch

**Figure 19 - Blower Controls**

## ⚠ WARNING

The blower must be plugged directly into a properly grounded three-prong receptacle, 120 VAC, 60 Hz, single phase. Do not cut or remove the grounding prong from this plug. Do not route power cord under or in front of appliance.

Installation must be in accordance with National Electrical Code, ANSI/NFPA 70 - latest edition. In Canada, the current CSA C22.1 Canadian Electrical Code - latest edition.

**DANGER: Disconnect power before servicing blower.**

In the event that you remove the blower for any reason, make sure a cover plate (available from IHP) is installed before using the heater. Excessive rear wall temperatures will result if the stove is burned without the cover plate. The cover plate is not necessary if a blower has never been installed because a knock-out will be in place to act as the cover.

### Blower Wiring Schematic

NOTE: SWITCH CONDITIONS GIVEN AT ROOM TEMPERATURE

N/C = NORMALLY CLOSED  
N/O = NORMALLY OPEN

— = FEMALE DISCONNECT  
— = MALE DISCONNECT  
○ = STUD CONNECTION

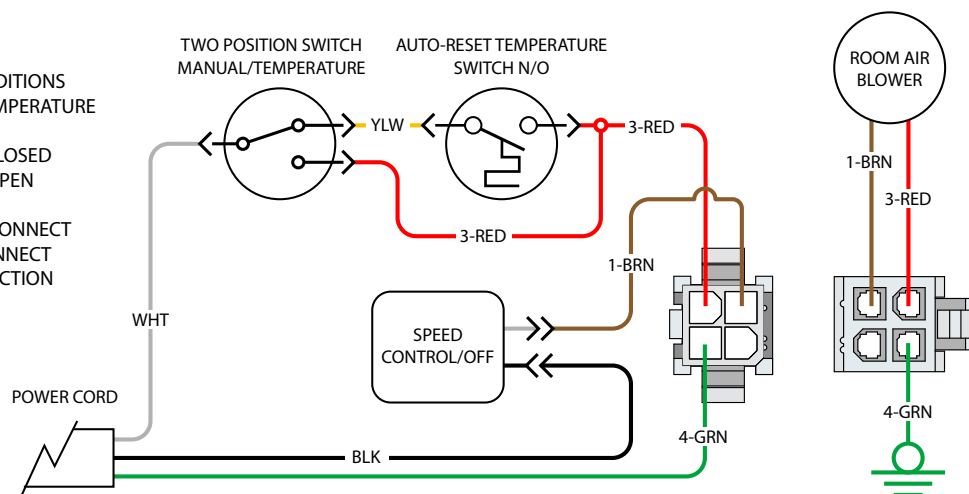

**Figure 18**

NOTE: DIAGRAMS & ILLUSTRATIONS ARE NOT TO SCALE.

## OPERATING TECHNIQUES AND HINTS

Recent developments in wood-burning technology have made wood-burning a cleaner and more convenient way to heat your home. Overall efficiency in a wood-burning appliance is a combination of combustion efficiency and heat transfer efficiency. Whether heating your entire home, or just a room or two, your understanding of how to best operate your stove or insert will enhance its overall efficiency and performance. What this can mean to you is longer, cleaner burns, less wood use and more heat.

## GETTING THE MOST OUT OF YOUR STOVE

The following sections will outline techniques you can use to “get the most out of your stove.” Please read them carefully.

## MAXIMIZING YOUR STOVE’S OVERALL EFFICIENCY

**It is important to know that for high, combustion efficient, clean burns, you will need to have sufficient temperatures inside the firebox for thorough combustion.** The best method for determining if you have sufficient temperatures is to watch the brick lining in your firebox. When you first light your stove or fireplace insert, the firebrick will turn a dark brown or black. After 20 to 30 minutes of a hot fire, most of the bricks should return to near their original light brown or yellow color. This means the firebrick have reached a high enough temperature for your stove to achieve high combustion efficiency.

**Second and just as important, is achieving a high level of heat transfer efficiency.** Slowing the rate of flow through the stove or insert enhances heat transfer, thus allowing more time for heat to be transferred into your home. To do this, be sure to thoroughly preheat your stove and then reduce the amount of primary air by closing the draft control (lower left) to about 1/2” open to fully closed. This will decrease the excess oxygen in your flue, which carries heat up your chimney, but should still be enough air to allow the stove to produce its maximum heat output. (More air may produce a lightly greater amount of heat, but will greatly increase wood consumption). When the area being heated reaches a comfortable temperature, slow the burn rate by closing the control to further improve heat transfer.

To get the most out of your appliance, you will need to combine good combustion efficiency with good heat transfer practices. The following are some tips on how to operate your stove to achieve the highest overall efficiency.

1. Thoroughly preheat your stove before slowing the burn rate by closing the draft control.
2. Measure the stove temperature at the hottest point on the stove top or face. Use this information to repeat burn rates.
3. Once preheated, add wood (if needed) and partially close the draft control (lower left).
4. Operate your stove as much as possible in the low to medium burn ranges.
5. Do not lower the draft setting so low as to completely extinguish the flames in the firebox. Check for at least some small flames 20 minutes after setting the draft control.
6. Do not continually operate your stove or fireplace insert in the high (wide open) setting. This wastes wood by carrying a great deal of heat up the chimney and can damage your stove or fireplace insert and chimney.
7. Go outside and check your chimney. More than a very small amount of smoke indicates wasted heat, creosote build-up and pollution.

## ACHIEVING CLEAN, LONG BURNS

**To achieve long burn times, after having thoroughly preheated the appliance, let the appliance top cool down to 275 to 400 degrees.** Now load the firebox and set the draft control. At this point, you may need to burn the stove with the draft open for a few minutes to ignite the wood. All IHP stoves are EPA tested for emissions at low burn with the air control completely closed. Whether or not you should burn your stove with the air control completely closed will depend on the following factors.

- \* How you load your wood
- \* Your chimney type, height and draft
- \* Your wood type and its moisture content
- \* The temperature of the appliance
- \* Which model stove or insert you have

**Experiment with different loading configurations to achieve longer burns.** Try loading the wood from side to side and nesting it in the ashes to prevent airflow under and around the wood. Fresh wood should be loaded to the back of the firebox or to the sides. Hot coals or half burned wood should be brought towards the front of the firebox. The way you load your wood can seriously affect burn times. If the new load does not ignite within a few minutes, try crisscrossing the load to allow more airflow around the fire, or try a slightly hotter stove temperature.

**Determining the lowest setting for efficient low burns.** This will require some experimentation on your part. Try closing the air control all the way with the stove temperature at 325 to 350 degrees. If the flames are completely extinguished, open the air control halfway and then slowly close it until there is only a small amount of flame. It is important to check the stove about 20 minutes after setting the draft control as it takes this long for the stove temperature to stabilize. There should still be some small flames on or above the wood load.

**Use 325 degrees as a starting point.** You can try starting temperatures 25 degrees higher or lower to achieve desired burn times, start 25 degrees lower if the stove burns the wood too quickly or 25 degrees higher if there are no flames in the firebox for more than a few minutes after loading the wood. You may or may not need to burn the stove with the air control open for a few minutes prior to setting the draft for a low burn, this will depend on the factors mentioned above. **Be sure not to smolder a fire overnight. Check your chimney for large amounts of smoke as this indicates very poor combustion.**

**It is important to realize that stove technology has changed.** Stoves have changed a great deal in the last few years. This has led to substantial changes in the methods of operation in new stoves as compared to older stoves. In old stoves without full brick linings and ceramic insulation, the rule was “get the stove as hot as possible before setting the draft on low for overnight burns.” On newer, high technology stoves, this is not necessary. Although it is still important to have the stove hot enough to burn efficiently, it will require less preheating. Once you have determined your optimum operating temperatures for various burn rates, we believe you will find your stove an extremely convenient way to achieve your heating needs.

**Do not reload the stove for long burns when the stainless secondary tubes or baffles are glowing red, or when the stove is uncomfortably hot to load.** This indicates the stove is too hot to load for a long burn. Also, do not load wood for a long burn on a deep bed of hot coals. Try stirring the coals a few minutes before loading the stove for a low burn to allow some of the unburned coals time to burn.

## MAINTENANCE

**Have your product inspected at least once a year by a qualified service technician to ensure gaskets, air tubes, baffles, and venting are in good repair to ensure proper performance. Have degraded items replaced by a qualified service technician.**

**THIS WOOD HEATER NEEDS PERIODIC INSPECTION AND REPAIR FOR PROPER OPERATION. IT IS AGAINST FEDERAL REGULATIONS TO OPERATE THIS WOOD HEATER IN A MANNER INCONSISTENT WITH OPERATING INSTRUCTIONS IN THIS MANUAL.**

**DOOR HINGES:** If door hinges need lubricating, use an anti-seize compound (never use oil) available from your IHP dealer.

**DOOR LATCH:** If your door latch fails to latch tightly and the gasket is in good condition, place a length of pipe (cheater bar) over the inside portion of the door handle and bend slightly toward the door until the proper adjustment is obtained. If the door handle does not close easily, apply high temperature anti-seize to the striker.

**DOOR GASKET:** Periodically check gasket to make sure it is not over-compressed. If compressed, replace with an IHP approved woven door rope. (Don't try substituting rope, only use an IHP approved door rope).

**PLATED ACCESSORIES:** Clean only with household type glass cleaner and a very soft cotton cloth. Other products may damage plated finish, paint and gaskets.

**BAFFLE BLANKET:** Your baffle blanket should be inspected during every chimney cleaning. If the baffle blanket is compressed or heavily stained, it should be replaced. Heavy creosote stains or matting is an indication of improper use and your burning habits should be reviewed.

**GLASS CLEANING:** Only clean glass with products specifically made to use on wood stoves. Other products could damage gaskets and paint. Never scrape glass with a razor blade. This can pit the glass and make it impossible to clean in the future.

**WINDOW GASKET:** The window gasket can be checked by running the flame of a match near the gasket and around the door. If the flame is drawn in around the window, the gasket should be replaced.

**DOOR HANDLE:** Door handle may become tight as you use the stove. Free the handle up by using dry graphite supplied with the stove. The directions are included with the graphite.



## WARNING

**Inspect and clean chimney and connector frequently. Under certain conditions of use, creosote buildup may occur rapidly.**

## GLASS REPLACEMENT INSTRUCTIONS

- Step 1. Remove Door Assembly** - Open door to remove E clip from the upper hinge pin. Remove upper hinge pin by pulling up while holding the opposite side of the door. Lift door out of the lower hinge pin and place face down on a soft surface.
- Step 2. Remove Door Back Screws (6 ea.)** - Using a 5/32" allen wrench remove the 6 retainer screws from the faceplate. To locate screws, peel back the door gasket as necessary.
- Step 3. Disassemble Door Assembly** - Flip door assembly over to be face up. Separate faceplate from door back by pulling up on faceplate.
- Step 4. Remove Glass** - Carefully remove broken glass one piece at a time (protective gloves are recommended)
- Step 5. Install New Glass Assembly** - Install the new glass with gasket in recess on door back (use only factory supplied 5mm ceramic glass. Do not substitute).
- Step 6. Reinstall Faceplate and Screws** - Reinstall faceplate onto door back and while holding the door assembly together flip the assembly back onto it's face. Carefully reinstall the screws. Be very careful not to overtighten the screws (this could result in glass breakage when the appliance is hot) and it is highly recommended to use anti seize on the screws.
- Step 7. Reinstall Door** - Set door assembly back into the lower hinge mount while holding the handle side of the door up. Place the upper hinge pin back in the mount and door assembly. Reinstall the E clip that was removed.

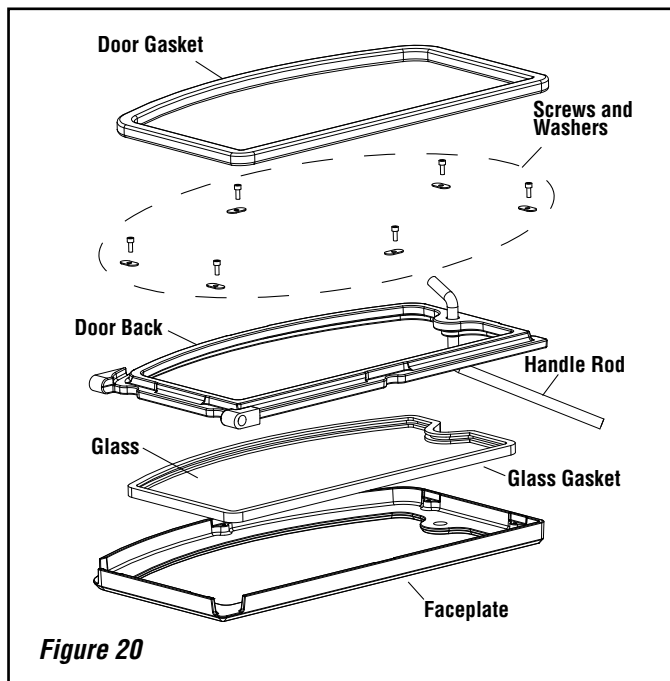

Figure 20

## GLASS CLEANING GUIDELINES

### WARNING: DO NOT CLEAN GLASS WHEN APPLIANCE IS HOT!

Glass on any wood stove or fireplace insert will not stay perfectly clean. Here are some guidelines for cleaning and caring for the glass:

- **Ensure the appliance is cold prior to cleaning glass.**
- This appliance is designed to provide a flow of air over the inside of the glass, where along with high heat helps inhibit build-up on the glass. When build-up occurs, a commercial glass cleaner designed for stoves is recommended. Regular household glass cleaners will not clean creosote.
- Do not use abrasives such as steel pads, steel wool or oven cleaner as they will scratch the glass. Never scrape glass with a razor blade as this may pit the glass and make it impossible to clean in the future.
- Do not use chemical glass cleaners as they may damage the gaskets or painted surfaces.

### TIPS FOR KEEPING THE GLASS CLEAN

- Burn only dry seasoned cord wood. **Wet wood = Dirty glass.**
- A short, hot fire (15 - 20 minutes) may help to clean off some of the normal buildup. **Lower burns = more build-up. Higher burns = less build-up.**
- Keep freshly loaded wood away from the glass.
- After reloading, allow all the wood to catch flame before dampering down the appliance.

## CAUTION

**Cleaning Glass: Ensure appliance is cold prior to cleaning glass. A commercial glass cleaner designed for stoves is recommended. Do not use abrasive cleaners. Do not clean with any materials, which may scratch or otherwise damage the glass. Scratches on the glass can develop into cracks or break. Inspect the glass regularly. If you detect a crack, extinguish the fire and contact your dealer for a replacement.**

## TROUBLESHOOTING

| <b>Problem</b>                       | <b>Solution</b>   |
|--------------------------------------|---|
| <b>POOR DRAFT:</b>                   | Extend chimney in length or have the chimney realigned to the proper size flue. Oversized chimneys normally have poor drafts. Remember, the appliances' draft depends solely on the natural draft of the chimney (See Draft Requirements on <b>Page 4</b> ). If your stove or fireplace insert is not drafting properly, your chimney is the problem. All stoves are thoroughly tested to ensure proper draft with the correct size chimney flue. |
| <b>EXCESSIVE DRAFT:</b>              | With better chimneys being more common, excessive draft can be an issue. Alleviate excessive draft by slowing the burn rate of the appliance once it has reached proper operating temperature (See Maximizing Your Stoves Overall Efficiency on <b>Page 19</b> ).   |
| <b>DIRTY GLASS:</b>                  | <ol style="list-style-type: none"><li>1) Burn smaller, hotter fires and check to make sure you are not setting the draft down too far with the draft control.</li><li>2) Make sure your wood is well-seasoned and dry (not open to rain - see Creosote and Fuel sections on <b>Pages 5-6</b>).</li><li>3) See Poor Draft section (above) and Cleaning Glass on <b>Page 20</b>.</li></ol>  |
| <b>SMOKES WHEN DOOR IS OPEN:</b>     | <ol style="list-style-type: none"><li>1) If smoke is entering the room, check to make sure your baffle boards are properly installed and that the baffle blanket is pushed back flush with the front of the baffle boards.</li><li>2) Check the chimney for blockage due to creosote (see Chimney and Creosote sections on <b>Pages 5 and 7</b>).</li><li>3) Check draft (See POOR DRAFT section above).</li></ol>                                |
| <b>WOOD BURNS TOO FAST:</b>          | <ol style="list-style-type: none"><li>1) The draft control must be closed further.</li><li>2) Add fuel at lower firebox temperatures.</li><li>3) Load wood side to side and reduce the flow of air under wood.</li><li>4) The door seal may need replacing, check for leakage.</li><li>5) See "Excessive Draft."</li></ol>  |
| <b>POOR HEAT OUTPUT:</b>             | <ol style="list-style-type: none"><li>1) Check your wood. Wet, moist, unseasoned wood will not produce heat.</li><li>2) Your stove or fireplace insert needs to be seasoned (moisture removed from the steel and brick). Continue to burn a fire. It normally takes from one to three weeks of burning to season your stove (See Burn-In Period on <b>Page 6</b>).</li><li>3) See Excessive Draft section above.</li></ol>                        |
| <b>PAINT GIVES OFF ODOR (smoke):</b> | Paint is tempering-in. Burn only moderately hot for the first few days until paint is fully cured. Then burn a very hot fire to cure any paint that may not easily cure. Open windows or door to ventilate (See Burn-In Period on <b>Page 6</b> ).  |

## DO'S AND DON'TS

- DO NOT:** Install or operate the appliance before reading this manual.
- DO NOT:** Close the draft beyond the point at which the flames are completely extinguished.
- DO NOT:** Open the appliance door without fully opening the draft first.
- DO NOT:** Burn driftwood or wood that has been in salt water. This includes some mill ends and scrap lumber that has been floated in salt water on the way to the mill. (This will void your warranty).
- DO NOT:** Handle the plated faceplate unnecessarily. Use the door handle only.
- DO NOT:** Force oversized logs into the firebox as this may dislodge the baffle assembly.
- DO NOT:** Close the door tightly during Burn-In Period.
- DO:** Be sure to clean any fingerprints from optional accessories that have plated surfaces before burning the appliance. Clean the plated surfaces only with household type glass cleaner and a very soft cloth.
- DO:** Consult local building department if other than recommended clearances are desired.
- DO:** Read instructions for the baffle boards and baffle blanket occasionally to ensure you have not bumped or moved them out of place when loading wood.
- DO:** Check the chimney and baffle monthly to make sure they are clean.
- DO:** Burn seasoned, dry wood only! (RAIN = WET WOOD)
- DO:** Open the door frequently during Burn-In Period to keep gasket from adhering to the curing paint.
- DO:** Enjoy the warm feeling of your new IHP appliance.

## Smoke Detector Recommended

Since there are always several potential sources of fire in any home, we recommend installing smoke detectors. If possible, install the smoke detector in a hallway adjacent to the room (to reduce the possibility of occasional false activation from the heat produced by these appliances). If your local code requires a smoke detector be installed within the same room, you must follow the requirements of your local code. Check with your local building department for requirements in your area.

## Carbon Monoxide Monitor Recommended

**Carbon Monoxide Poisoning:** Early signs of carbon monoxide poisoning are similar to the flu with headaches, dizziness and/or nausea. If you have these signs, obtain fresh air immediately. Some people are more affected by carbon monoxide than others, including pregnant women, people with heart or lung disease or anemia, those under the influence of alcohol, and those at high altitudes.

**It is against federal regulations to operate wood heaters in a manner inconsistent with operating instructions in the manual.**

## PROHIBITED FUELS

This heater is designed to burn natural wood only. Higher efficiencies and lower emissions generally result when burning air dried seasoned hardwoods, as compared to softwoods or to green or freshly cut hardwoods. **DO NOT BURN:**

- **Garbage;**
- **Lawn clippings or yard waste;**
- **Materials containing rubber, including tires;**
- **Materials containing plastic;**
- **Waste petroleum products, paints or paint thinners, or asphalt products;**
- **Materials containing asbestos;**
- **Construction or demolition debris;**
- **Railroad ties or pressure-treated wood;**
- **Manure or animal remains;**
- **Salt water driftwood or other previously salt water saturated materials;**
- **Unseasoned wood;**
- **Christmas tree branches;**
- **Paper products, colored paper, cardboard, plywood, or particle-board;**
- **gasoline;**
- **naphtha;**
- **engine oil;**
- **flammable liquids;**
- **solvents;**
- **grease; or**
- **coal**

The prohibition against burning these materials does not prohibit the use of fire starters made from paper, cardboard, saw dust, wax and similar substances for the purpose of starting a fire in an affected wood heater.

Burning these materials may result in release of toxic fumes or render the heater ineffective and cause smoke. Intense firing with these materials may overheat the fireplace, causing damage to the unit, a fire or even possibly igniting a chimney fire if the chimney is creosoted. Burning unapproved fuel, resulting in excessive pollutants being emitted, may be prohibited and subject to a fine or other penalty by the authority having jurisdiction in your area.

## REPLACEMENT PARTS - MODELS S160TGL AND S160AGL

Contact an IHP dealer to obtain any of these parts. Never use substitute materials. Use of non-approved parts can result in poor performance and safety hazards.

| FRONT DOOR PARTS LIST            |         |  |
|----------------------------------|---------|--|
| Item #                           | Cat. No | Description  |
| 1                                | H5639   | Door Rope Kit, 7/8" Dia. (6' 2")                       |
| 2                                | H5629   | Upper Hinge Pin  |
| 3                                | H5625   | Upper Hinge Pin E-Clip                                 |
| 4                                | H5628   | Lower Hinge Pin  |
| 6                                | H5640   | Glass Gasket Kit (8' 4")                               |
| 7                                | H5577   | Set of 6 screws and 6 washers for door assembly        |
| 8                                | H5654   | Spring Handle / Nickel                                 |
| 9                                | 71067   | Traditional Door Glass / Plain                         |
| 10                               | 71057   | Traditional Door Faceplate / Black                     |
|                                  | 71059   | Traditional Door Faceplate / Nickel                    |
|                                  | 71145   | Traditional Door Faceplate / Brushed Nickel            |
| 11                               | 71072   | Arch Door Glass / Plain                                |
| 12                               | 71060   | Arch Door Faceplate / Black                            |
|                                  | 71062   | Arch Door Faceplate / Nickel                           |
|                                  | 71144   | Arch Door Faceplate / Brushed Nickel                   |
| 13                               | H5579   | Traditional Door Back w/ Handle (door gasket included) |
| 14                               | H5578   | Arch Door Back w/ Handle (door gasket included)        |
| ASH DRAWER PEDESTAL AND PEDESTAL |         |  |
| 15                               | H5514   | Small & Large Pedestal Rear Block Off Plate w/ Hole    |
| 16                               | H5557   | Ash Drawer for Small Pedestal                          |
| 17                               | H5564   | Ash Plug Remover and Rake                              |
| 18                               | H5516   | Aluminum Flex Tubing Kit w/ clamp (15" of 4" dia.)     |
| 19                               | H5565   | 6" x 6-1/2" Rodent Screen                              |

| LEGS AND LEG PARTS              |       |  |
|---------------------------------|-------|--|
| 18                              | H5516 | Aluminum Flex Tubing Kit w/ clamp (15" of 4" dia.)                               |
| 20                              | H5558 | Single Black Cascade Leg   |
| 21                              | H5669 | Single Black Olympic Leg   |
|                                 | H5621 | Single Nickel Olympic Leg  |
|                                 | H5619 | Single Brushed Nickel Olympic Leg  |
| 22                              | H5649 | Heatshield / Leg Fastener Kit  |
| 23                              | 71110 | Bottom Heatshield / S160TGL AND S160AGL  |
| 24                              | H5662 | Cascade / Olympic Leg Kit Outside Air Plenum Box                                 |
| FSB BLOWER PARTS                |       |  |
| 25                              | H8062 | FSB700 Blower Only Assembly w/ blower wiring harness                             |
| 26                              | H5658 | Fan Blade (FSB700)   |
| 27                              | H5657 | Fan Cage (FSB700)  |
| 28                              | H8063 | FSB700 Blower Only Wire Harness  |
| 29                              | H8064 | Snap Switch w/gasket and screws  |
| 30                              | H5742 | Speed Control - High Temperature (FSB700)  |
| 31                              | H8065 | Control Panel Assembly w/ Snap Switch Housing Assembly                           |
| 32                              | H8066 | Control Switch (Manual, Off, Automatic)  |
| S160TGL AND S160AGL STOVE PARTS |       |  |
| 33                              | H5627 | Removable Inner Flue Collar Ring   |
| 34                              | F1871 | IronStrike® Nameplate Kit w/ Hardware - Nickel                                   |
| 35                              | H5650 | Draft Rod Knob   |
| 36                              | H8081 | Ash Block Off - Hearthplate  |
| 37                              | H5661 | Cast Iron Ash Plug   |
| 38                              | H5582 | 1/2 Cut Brick for Ash Removal  |
| 39                              | H5612 | Firebrick 4-1/2" x 9" (10 per stove)   |
| 40                              | H5576 | Firebrick 4-1/4" x 9" (2 per stove)  |
| 41                              | H5607 | Firebrick 2-1/4" x 9" (3 per stove)  |
| 42                              | H3095 | Firebrick 2-1/4" x 8-7/8" (1 per stove)  |
| 43                              | H5604 | Firebrick 1-1/2" x 9" (1 per stove)  |
| 44                              | H5597 | Firebrick 1-1/2" x 8-7/8" (1 per stove)  |
| 50                              | F4091 | Complete Firebrick Kit   |
| 45                              | H3104 | Front Secondary Burn Tube Assembly   |
| 46                              | H3105 | Middle/Rear Secondary Burn Tube Assembly   |
| 47                              | H3103 | Complete Secondary Burn Tube Assembly (includes tubes and all mounting hardware) |
| 48                              | H8017 | Baffle Blanket 20" x 11" x 1"  |
| 49                              | H8016 | Baffle Board Kit w/ Baffle Blanket   |
| MISCELLANEOUS PARTS             |       |  |
|                                 | 71052 | Dry Graphite (Apply to door handle and door hinges)                              |
|                                 | H5633 | Anti Seize 2 gram pouch  |

REPLACEMENT PARTS - MODELS S160TGL AND S160AGL

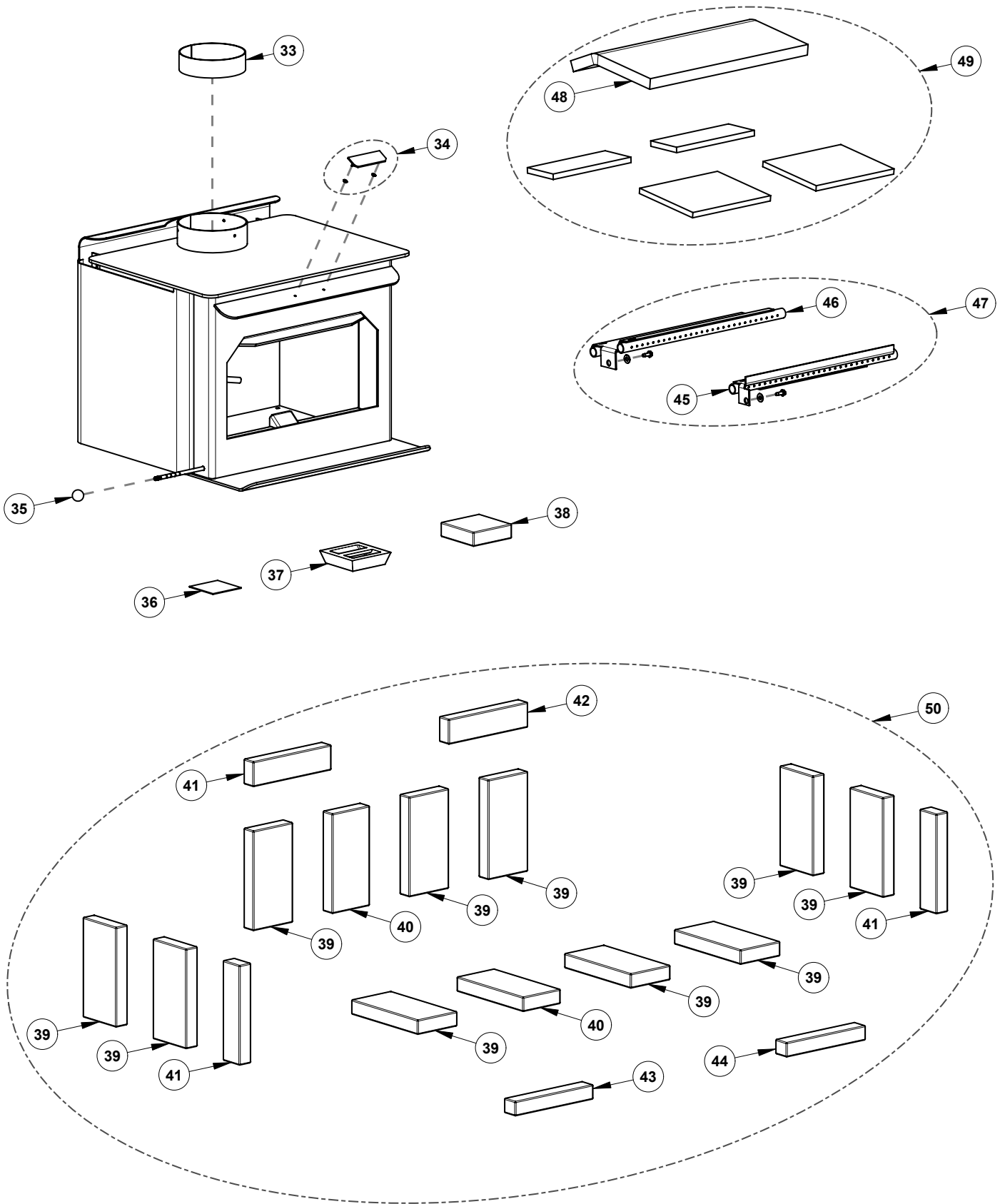

NOTE: DIAGRAMS & ILLUSTRATIONS ARE NOT TO SCALE.

# REPLACEMENT PARTS - MODELS S160TGL AND S160AGL

## Door Parts

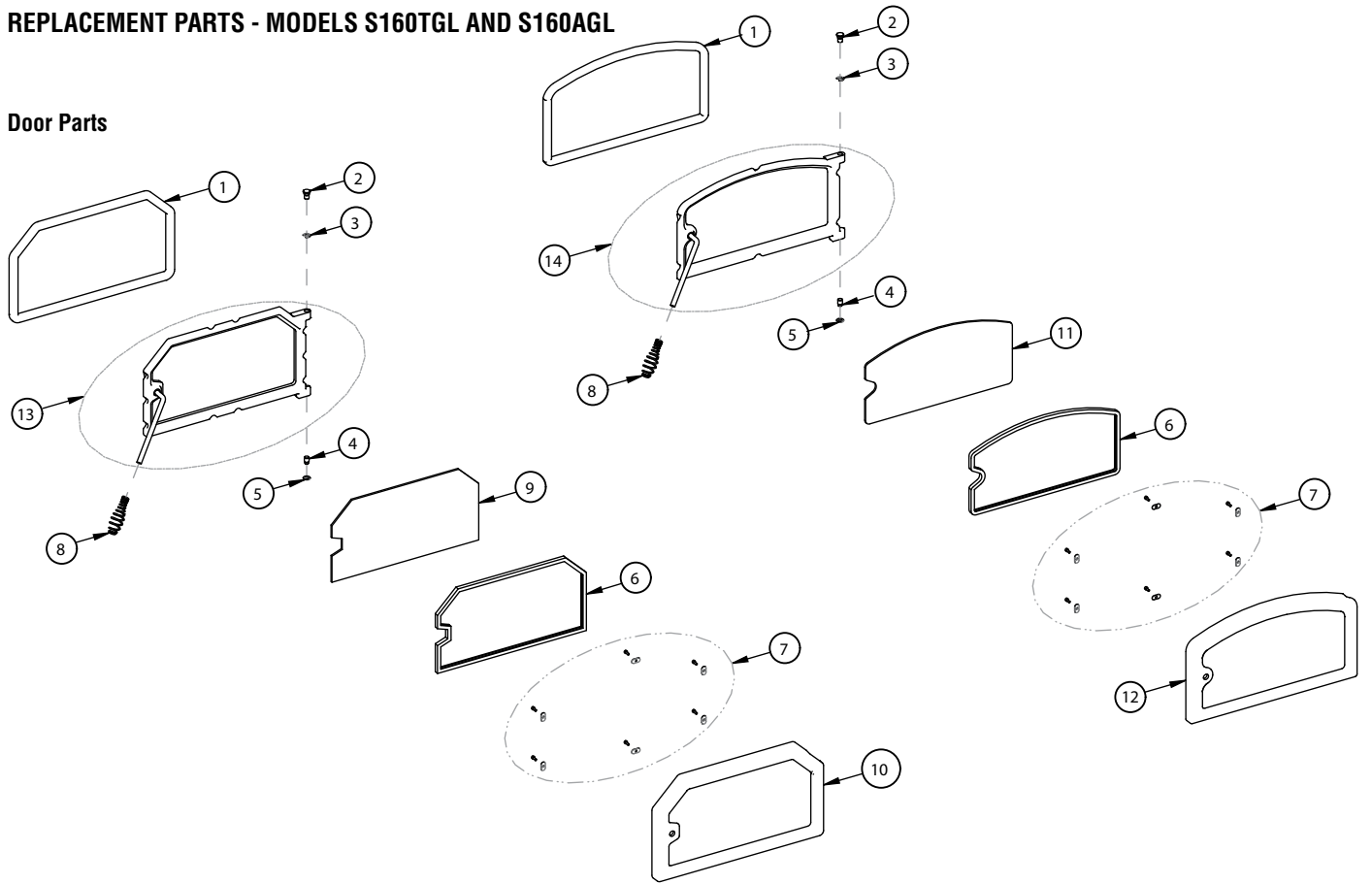

## Blower Parts

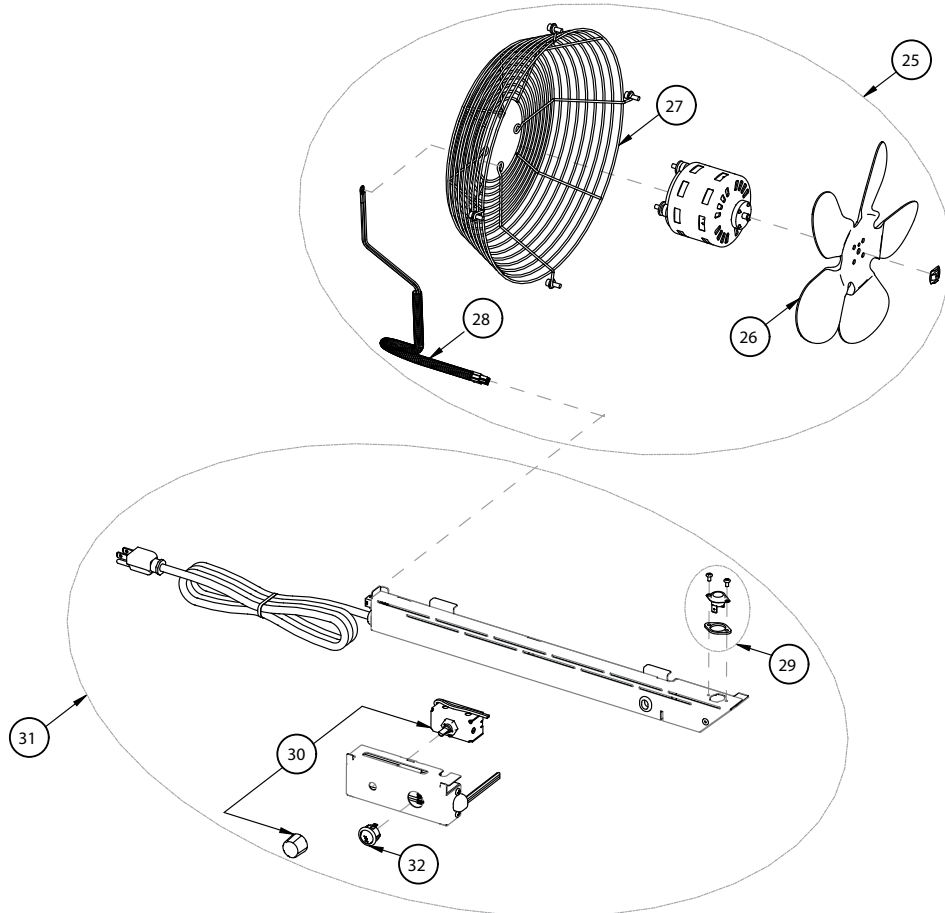

# REPLACEMENT PARTS - MODELS S160TGL AND S160AGL

## Leg and Leg Parts

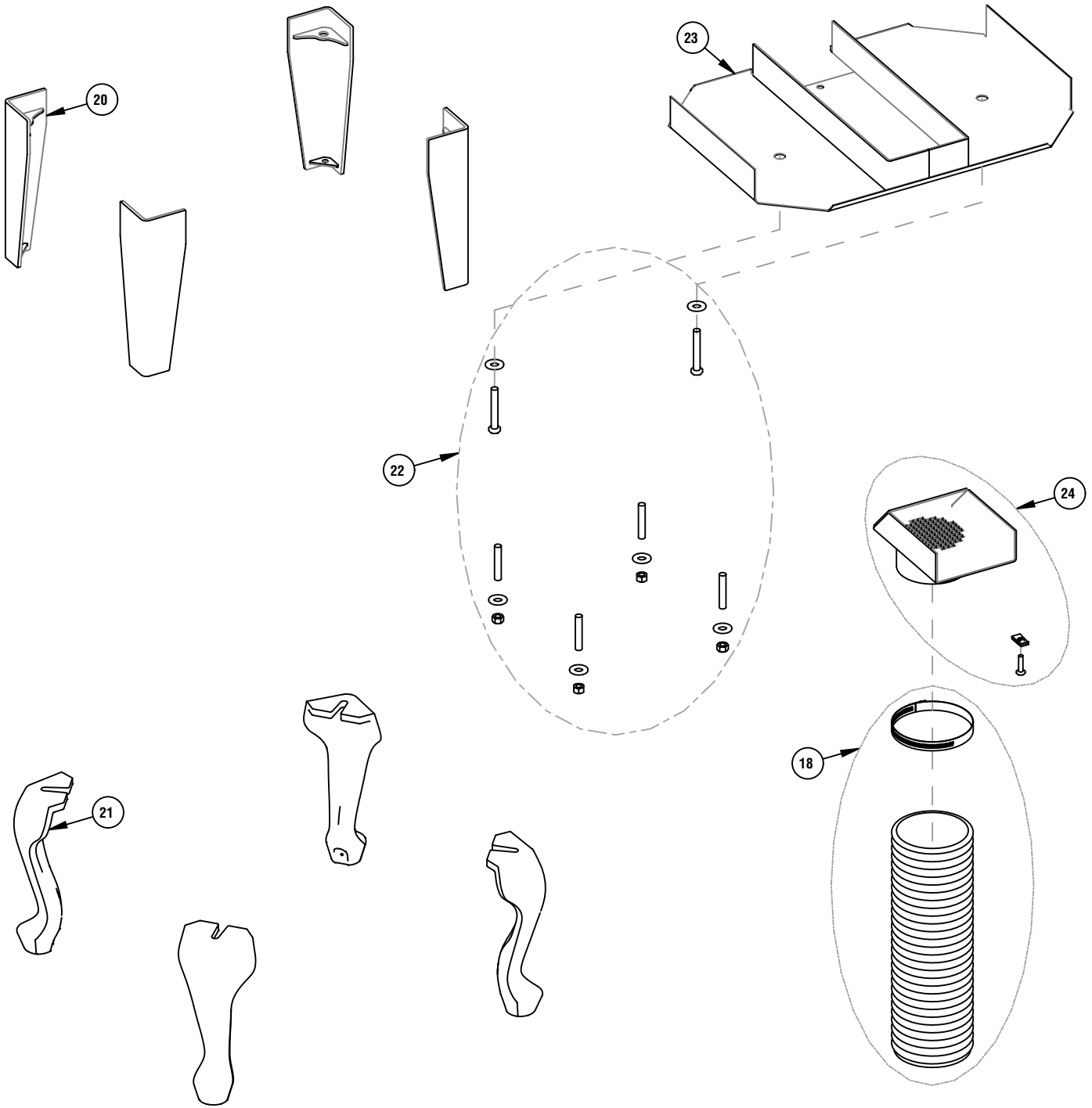

REPLACEMENT PARTS - MODELS S160TGL AND S160AGL

Ash Drawer Pedestal and Pedestal

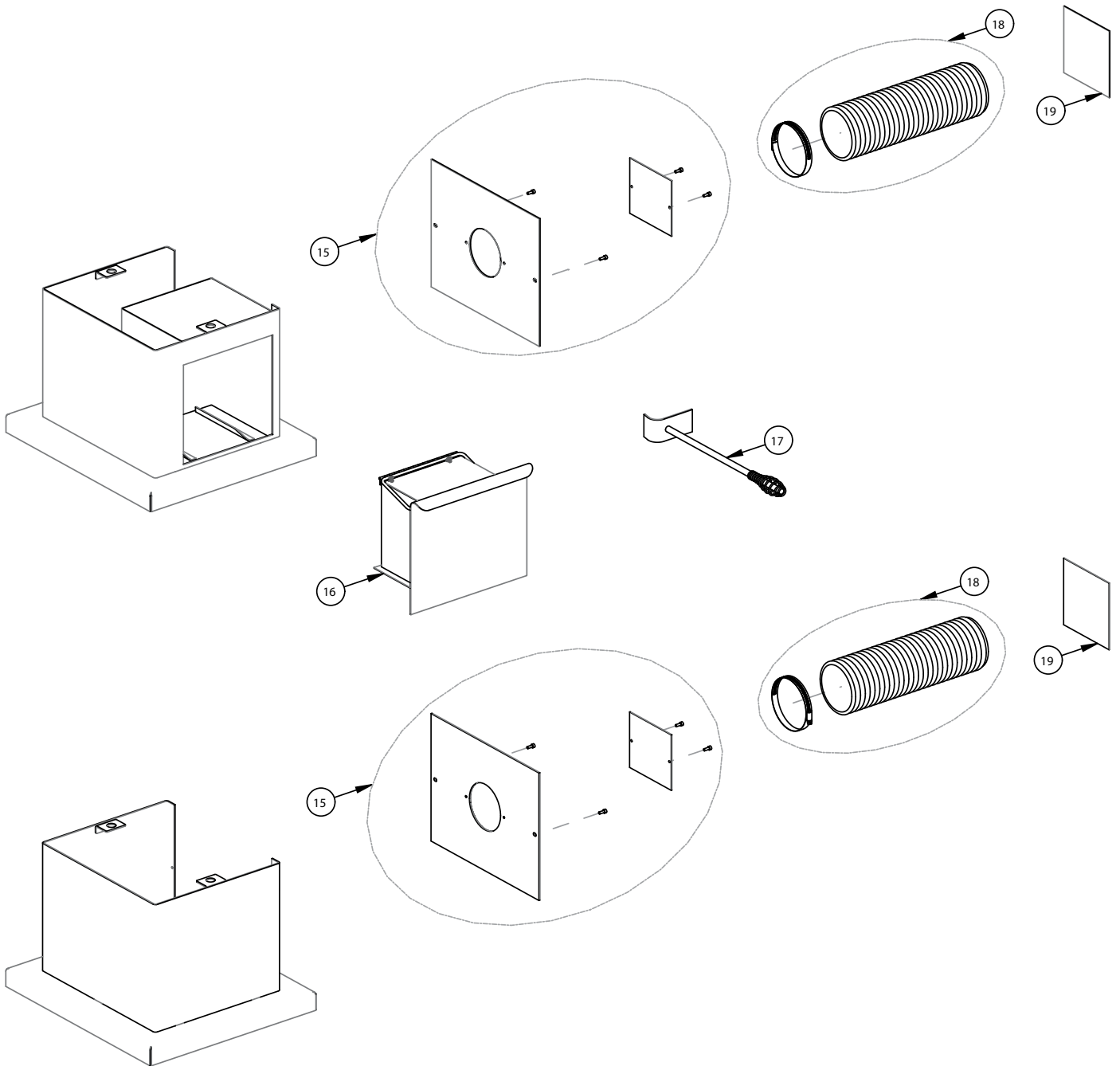

**ACCESSORIES - MODELS S160TGL AND S160AGL**

| Product Reference Information |  |                     |                     |
|-------------------------------|--|---------------------|---------------------|
| <i>Cat. No.</i>               | <i>Description</i>   | <i>Ship. Weight</i> | <i>Ship. Volume</i> |
| H7884                         | S160TGL, Stove / Traditional Black Door / Nickel Nameplate | 313 lb.             | 18.91 cu. ft.       |
| H7883                         | S160AGL, Stove / Arch Black Door / Nickel Nameplate        | 313 lb.             | 18.91 cu. ft.       |

| PEDESTALS (REQUIRED)             |                         |  |
|----------------------------------|-------------------------|--|
| <b>Cat. No.</b>                  | <b>Model</b>            | <b>Description</b>   |
| 71108                            | WS-PED                  | Pedestal <i>(ref. form #506033-16)</i>   |
| 71109                            | WS-PED-ASHD             | Ash Drawer Pedestal <i>(ref. form #506033-15)</i>  |
|                                  |                         | or LEGS (Required) <i>(ref. form #506033-14)</i>   |
| 70000                            | LEG-OLY-B               | Olympic Sculptured Black (4 per pkg.)  |
| 70002                            | LEG-OLY-N               | Olympic Sculptured Nickel (4 per pkg.)   |
| 70008                            | LEG-OLY-BRN             | Olympic Sculptured Brushed Nickel (4 per pkg.)   |
| 70003                            | LEG-CAS-B               | Cascade Steel Black (4 per pkg.)   |
| HEAT SHIELD (REQUIRED WITH LEGS) |                         |  |
| 71110                            | WSHS-160                | Heat Shield <i>(ref. form #506033-14)</i>  |
| BLOWER                           |                         |  |
| H7917                            | BLWR-FSB700-SS          | Blower Kit, FS Woodstoves  |
| OUTSIDE AIR KITS                 |                         |  |
| 71111                            | OUTAIRK-L               | Outside Air Kit / Leg <i>(ref. form #506033-18)</i>  |
| 71112                            | OUTAIRK-P               | Outside Air Kit / Pedestal <i>(ref. form #506033-17)</i>   |
| MISC.                            |                         |  |
| 71054                            | Paint Nickel (1/2 Pint) | Paint Nickel (1/2 pint)  |
| F5035                            | ----                    | Touch Up Spray Paint, Hi-Temp Satin Black  |
| H5308                            | W-LEGF-LBRKT            | Leg Fastening L-Brackets (4 per pkg.) (Tie down kit to be used in mobile or modular homes) <i>(ref. form #506033-19)</i> |

**SAFETY / LISTING LABEL - MODELS  
S160TGL AND S160AGL - ENGLISH**

**CONTACT YOUR LOCAL BUILDING OR FIRE OFFICIALS ABOUT  
RESTRICTIONS AND INSTALLATION INSPECTION IN YOUR AREA.  
LISTED ROOM HEATERS, SOLID FUEL TYPE ALSO FOR USE IN  
MOBILE HOME INSTALLATION (USA ONLY) PURSUANT TO (UM) 84-HUD**

|                                       |            |                |
|---------------------------------------|------------|----------------|
| Model: S160GL<br>Report Number 14-186 | Serial No. | <b>S160GL-</b> |
|---------------------------------------|------------|----------------|



Manufactured By:  
INNOVATIVE HEARTH PRODUCTS  
1769 East Lawrence Street  
Russellville, AL 35654 USA



**"PREVENT HOUSE FIRES"**

Install and use only in accordance with manufacturer's installation and operating instructions and your local building codes.

**CAUTION:** Special methods are required when passing chimney through a wall or ceiling, refer to local building codes. Do not connect this unit to a chimney flue serving another appliance.

**WARNING:** (MOBILE HOME USA Only) An outside air inlet must be provided for combustion, and be unrestricted while unit is in use. Do not install appliance in a sleeping room. The structural integrity of the mobile home floor, walls and ceiling/roof must be maintained. Approval void when label is missing. Replace glass only with 5mm ceramic.

To be installed as a freestanding room heater with the clearances in the manufacturer's installation instructions. Not to be installed in any factory-built fireplace.

This wood heater needs periodic inspection and repair for proper operation. Consult the owner's manual for further information. It is against federal regulations to operate this wood heater in a manner inconsistent with the operating instructions in the owner's manual.

Certified to comply with 2020 particulate emission standards using crib wood. - Emissions value: 1.7 grams/hr.

**Minimum Clearance to Combustible Materials - Inches (millimeters)**

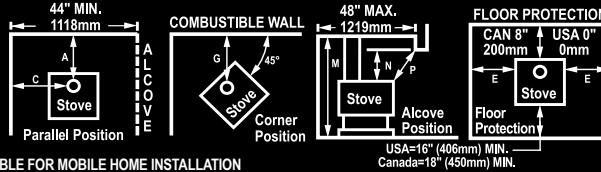

**SUITABLE FOR MOBILE HOME INSTALLATION**

| PIPE                  | INSTALLATION                          | A                 | C                 | E†       | G                   | M          | NⓈ        | PⓈ        |
|-----------------------|---------------------------------------|-------------------|-------------------|----------|---------------------|------------|-----------|-----------|
| Single Wall           | Residential or Alcove                 | USA-16" CAN-483mm | USA-21" CAN-610mm | 8" 200mm | USA-18" CAN-533mm   | 84" 2134mm | 30" 762mm | 36" 914mm |
| Single w/ Pipe Shield | Residential or Alcove                 | USA-10" CAN-330mm | USA-18" CAN-533mm | 8" 200mm | USA-13.5" CAN-419mm | 84" 2134mm | 30" 762mm | 36" 914mm |
| Double Wall           | Residential or Alcove or Mobile Home* | USA-10" CAN-330mm | USA-18" CAN-533mm | 8" 200mm | USA-13.5" CAN-419mm | 72" 1829mm | 30" 762mm | 36" 914mm |

† USA=8" (200mm) from door opening, Canada=8" (200mm) from sides and back of unit

Ⓢ Dimensions to Stove Body \* Mobile Home - USA only

ALCOVE DIMENSIONS (single wall pipe): Minimum 48" (1219mm) width, maximum 48" (1219mm) depth.

ALCOVE DIMENSIONS (double wall pipe): Minimum 44" (1117mm) width, maximum 48" (1219mm) depth.

FLOOR PROTECTOR: The hearth and/or floor protection must be a non-combustible hearth/floor protector with a minimum thickness of 3/8" (9.5mm), extending beneath the heater and to the front, sides, and rear as indicated.

**NOTICE:** A header constructed of COMBUSTIBLE material must meet both N & P clearances. All mobile home installations require outside air kits (OAK).

Clearance dimensions are to 6" (152mm) flue collar. If a single wall connector pipe with shield is used, a 1 inch air space is needed between pipe and shield. Shield attaches to rear of stove pipe and must run from stove top to ceiling. Pipe shield shall be UL listed.

**CHIMNEY & CONNECTOR:** Minimum 6" diameter, minimum 24 MSG black steel connector pipe with listed factory-built chimney suitable for use with solid fuels or masonry chimney. Horizontal connection not tested, refer to local building codes for installation. Restrictions apply! Read instructions before installing.

Minimum alcove width between combustibles: 44" with double wall pipe and 48" all other installations.

MOBILE HOME approved Class A - UL 103HT chimneys and double wall connectors:

- Security
- Metal Fab
- Projet
- Ameri-Tec
- Jakes Evans
- Metalbestos
- Dura-Vent
- Industrial Chimney

RESIDENTIAL chimney systems must be from the same brands as listed for mobile homes but connector pipe may be double wall, single wall or single wall with shield as listed above. Connector pipe and chimney must be of the same brand.

COMPONENTS REQUIRED FOR INSTALLATIONS: Legs AND Bottom Heat Shield or Pedestal Base attached as shown in the installation instructions. If optional blower is NOT used, Rear Heat Shield Block Off Plate shall be installed.



**CAUTION** \*HOT WHILE IN OPERATION. DO NOT TOUCH, KEEP CHILDREN, CLOTHING AND FURNITURE AWAY. CONTACT MAY CAUSE SKIN BURNS. SEE NAME-PLATE AND INSTRUCTIONS. DO NOT OVERFIRE - IF HEATER OR CHIMNEY CONNECTOR GLOWS, YOU ARE OVERFIRING. INSPECT AND CLEAN CHIMNEY FREQUENTLY - UNDER CERTAIN CONDITIONS OF USE, CREOSOTE BUILDUP MAY OCCUR RAPIDLY. DO NOT USE GRATE OR ELEVATE FIRE - BUILD WOOD FIRE DIRECTLY ON HEARTH. FEED DOOR MUST BE CLOSED DURING FIRING EXCEPT WHEN ADDING FUEL. KEEP ASH DOOR CLOSED TO AVOID EXCESS HEAT. DANGER: RISK OF ELECTRICAL SHOCK. DISCONNECT POWER BEFORE SERVICING UNIT. FOR USE WITH SOLID WOOD FUEL ONLY.

Date of Manufacture / Date De Fabrication

|      |      |      |      |      |      |      |     |      |      |      |      |     |     |     |
|------|------|------|------|------|------|------|-----|------|------|------|------|-----|-----|-----|
| 2026 | 2027 | 2028 | JAN. | FEB. | MAR. | APR. | MAY | JUN  | JUL  | AUG  | SEP  | OCT | NOV | DEC |
|      |      |      | JANV | FEVR | MARS | AVR  | MAI | JUIN | JUIL | AOÛT | SEPT | OCT | NOV | DEC |



U.S. ENVIRONMENTAL PROTECTION AGENCY

Certified to comply with 2020 particulate emission standards using crib wood. - Emissions value: 1.7 grams/hr.

Part No. 900902-01 Rev. 3, 08/2025 DO NOT REMOVE THIS LABEL Made in U.S.A.

# Innovative Hearth Products IronStrike® Brand Wood Burning Stove and Insert Limited Lifetime Warranty

## THE WARRANTY

Innovative Hearth Products ("IHP") Limited Lifetime Warranty warrants your IronStrike® Brand Wood Burning Stove or Insert ("Product") to be free from defects in materials and workmanship at the time of manufacture. The Product body, firebox and ceramic glass carry the Limited Lifetime Warranty. Ceramic glass carries the Limited Lifetime Warranty against thermal breakage only. After installation, if covered components manufactured by IHP are found to be defective in materials or workmanship during the Limited Lifetime Warranty period and while the Product remains at the site of the original installation, IHP will, at its option, repair or replace the covered components. If repair or replacement is not commercially practical, IHP will, at its option, refund the purchase price or wholesale price of the IHP product, whichever is applicable. IHP will also pay IHP prevailing labor rates, as determined in its sole discretion, incurred in repairing or replacing such components for up to five years. THERE ARE EXCLUSIONS AND LIMITATIONS to this Limited Lifetime Warranty as described herein.

## COVERAGE COMMENCEMENT DATE

Warranty coverage begins on the date of purchase. In the case of new home construction, warranty coverage begins on the date of first occupancy of the dwelling or six months after the sale of the Product by an independent IHP dealer/distributor, whichever occurs earlier. The warranty shall commence no later than 24 months following the date of product shipment from IHP, regardless of the installation or occupancy date.

## EXCLUSIONS AND LIMITATIONS

This Limited Lifetime Warranty applies only if the Product is installed in the United States or Canada and only if operated and maintained in accordance with the printed instructions accompanying the Product and in compliance with all applicable installation and building codes and good trade practices.

This warranty is non-transferable and extends to the original owner only. The Product must be purchased through a listed supplier of IHP and proof of purchase must be provided. The Product body and firebox carry the Limited Lifetime Warranty from the date of installation. Vent components, trim components and paint are excluded from this Limited Lifetime Warranty. The following do not carry a Limited Lifetime Warranty but are warranted as follows:

**Cast Iron Heat Exchanger** – Replacement for five years from the date of installation

**Cast iron parts** – Replacement for one year from the date of installation

**Catalyst** – Carries a separate warranty. Refer to the warranty certificate provided for that part

**Electrical components** – Repair or replacement for one year from date of installation

**Gaskets** – Replacement for one year from the date of installation.

**Gold & nickel plating** – Replacement for two years from date of installation. Excludes tarnishing

**Refractory & screens** – Replacement for two years from date of installation. Excludes hairline cracks

**Removable air tubes** – Repair or replacement for seven years from date of installation. IHP prevailing labor rates for years one through five.

**Labor coverage** – Prevailing IHP labor rates apply for the warranty period of the component, unless otherwise noted

**Parts not otherwise listed carry a 90 day warranty from the date of installation.**

**Whenever practicable, IHP will provide replacement parts, if available, for a period of 10 years from the last date of manufacture of the Product.**

IHP will not be responsible for: (a) damages caused by normal wear and tear, accident, riot, fire, flood or acts of God; (b) damages caused by abuse, negligence, misuse, or unauthorized alteration or repair of the Product affecting its stability or performance. (The Product must be subject to normal use with approved fuels listed in the Operation Manual provided with the product. Fuel products with abnormal burning characteristics, including but not limited to fuel such as driftwood, coal or plywood and wood products using a binder may burn at excessive temperatures and may cause damage to the Product or may cause it to function improperly; IHP stoves, inserts and high efficiency EPA fireplaces are approved for burning dry seasoned wood only.); (c) damages caused by failing to provide proper maintenance and service in accordance with the instructions provided with the Product; (d) damages, repairs or inefficiency resulting from faulty installation or application of the Product.

Coverage of this Limited Lifetime Warranty is conditional upon the appliance being operated without the use of grates, irons or any other method to elevate the fire.

IHP is not responsible for inadequate system draft caused by air conditioning and heating systems, mechanical ventilation systems, or general construction conditions which may generate negative air pressure in the room in which the appliance is installed. Additionally IHP assumes no responsibility for smoking conditions caused by inadequate chimney height, adjoining trees or buildings, adverse wind conditions or unusual environmental factors and conditions. Certain IHP Products are listed for use with Security Chimneys International, Ltd. chimney systems only. Use of chimney components other than that specified in the Product manual will void the Product warranty.

This Limited Lifetime Warranty covers only parts and labor as provided herein. In no case shall IHP be responsible for materials, components or construction which are not manufactured or supplied by IHP or for the labor necessary to install, repair or remove such materials, components or construction. Additional utility bills incurred due to any malfunction or defect in equipment are not covered by this Limited Lifetime Warranty. All replacement or repair components will be shipped F.O.B. from the nearest stocking IHP factory.

## LIMITATION ON LIABILITY

It is expressly agreed and understood that IHP's sole obligation and the purchaser's exclusive remedy under this warranty, under any other warranty, expressed or implied, or in contract, tort or otherwise, shall be limited to replacement, repair, or refund, as specified herein.

In no event shall IHP be liable for any incidental or consequential damages caused by defects in the Product, whether such damage occurs or is discovered before or after replacement or repair, and whether such damage is caused by IHP's negligence. IHP has not made and does not make any representation or warranty of fitness for a particular use or purpose, and there is no implied condition of fitness for a particular use or purpose.

IHP makes no expressed warranties except as stated in this Limited Lifetime Warranty. The duration of any implied warranty is limited to the duration of this expressed warranty.

No one is authorized to change this Limited Lifetime Warranty or to create for IHP any other obligation or liability in connection with the Product. Some states and provinces do not allow the exclusion or limitation of incidental or consequential damages, so the above limitations or exclusions may not apply to you. The provisions of this Limited Lifetime Warranty are in addition to and not a modification of or subtraction from any statutory warranties and other rights and remedies provided by law.

## INVESTIGATION OF CLAIMS AGAINST WARRANTY

IHP reserves the right to investigate any and all claims against this Limited Lifetime Warranty and to decide, in its sole discretion, upon the method of settlement.

To receive the benefits and advantages described in this Limited Lifetime Warranty, the appliance must be installed and repaired by a licensed contractor approved by IHP.

Contact IHP at the address provided herein to obtain a listing of approved dealers/distributors. **IHP shall in no event be responsible for any warranty work done by a contractor that is not approved without first obtaining IHP's prior written consent.**

## HOW TO REGISTER A CLAIM AGAINST WARRANTY

In order for any claim under this warranty to be valid, you must contact the IHP dealer/distributor from which you purchased the product. If you cannot locate the dealer/distributor, then you must notify IHP in writing. IHP must be notified of the claimed defect in writing within 90 days of the date of failure. Notices should be directed to the IHP Warranty Department at 1769 East Lawrence Street; Russellville, AL 35654 or visit our website at [WWW.IRONSTRIKE.US.COM](http://WWW.IRONSTRIKE.US.COM).

## WARRANTY

Your wood appliance is covered by a limited warranty (provided with the appliance). Please read the warranty to be familiar with its coverage.

Retain this manual. File it with your other documents for future reference.

## REPLACEMENT PARTS

See **Page 24** for a complete replacement parts list. Use only parts supplied from the manufacturer.

Normally, all parts should be ordered through your IHP distributor or dealer. Parts will be shipped at prevailing prices at time of order.

When ordering repair parts, always give the following information:

1. The model number of the appliance.
2. The Serial Number of the appliance.
3. The part number.

4. The description of the part.
5. The quantity required.
6. The installation date of the appliance.

If you encounter any problems or have any questions concerning the installation or application of this system, please contact your dealer.

**Innovative Hearth Products (IHP)**  
**1769 East Lawrence Street**  
**Russellville, AL 35654**  
**IronStrike.us.com**

## PRODUCT REFERENCE INFORMATION

We recommend that you record the following important information about your appliance. If you did not purchase your appliance directly from an IHP dealer, then contact us at IronStrike.us.com to find your nearest IHP dealer who will answer your questions or address your concerns.

|                          |
|--------------------------|
| Model Number _____       |
| Serial Number _____      |
| Date Installed _____     |
| Your Dealer's Name _____ |

|   |  |  |
|---|--|--|
|  <p><b>NATIONAL<br/>FIREPLACE<br/>INSTITUTE</b><br/><b>NFI</b><br/><b>CERTIFIED</b><br/><a href="http://www.nficertified.org">www.nficertified.org</a></p> | <p>We recommend that our woodburning hearth products be installed and serviced by professionals who are certified in the U.S. by the National Fireplace Institute® (NFI) as NFI Woodburning Specialists or who are certified in Canada by Wood Energy Technical Training (WETT).</p> |  <p><b>Wood Energy<br/>Technical Training</b><br/><a href="http://www.wettinc.ca">www.wettinc.ca</a></p> |
|---|--|--|

Innovative Hearth Products (IHP) reserves the right to make changes at any time, without notice, in design, materials, specifications, and prices, and also to discontinue colors, styles, and products. Consult your local distributor for fireplace code information.

