

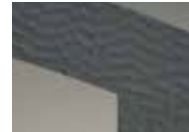

STANDARD FEATURES

- ◆ Circulating design features facade, arch doors and ceramic glass for optimum heat transfer
- ◆ EPA variable-rate certified and Washington State approved high-efficiency wood heater
- ◆ Spacious 4.0 cubic foot insulated firebox that accepts up to 30" log size for increased performance
- ◆ Steel double doors with heat resistant door handles that stay cool to the touch
- ◆ Stacked textured refractory panels with integrated ash lip and decorative cast iron log retainer
- ◆ Catalytic combustor for maximum performance
- ◆ Bypass control: Greater airflow during startup for faster wood ignition and no smoke spillage when reloading
- ◆ Includes insulated outside air kit (required for use)
- ◆ 80,000 BTUs and heats up to 2,500 square feet*
- ◆ Efficient air wash system that keeps glass clean
- ◆ Includes heat activated 200 CFM variable-speed blower for time-delayed heat distribution
- ◆ Durable high temperature paint finish
- ◆ Limited Lifetime Warranty

DOORS (Optional)



Hammered-Steel



Smooth

FACADE (Required)



Hammered-Steel



Smooth

BRICK



Textured Stacked Panels

APPLIANCE SPECIFICATIONS

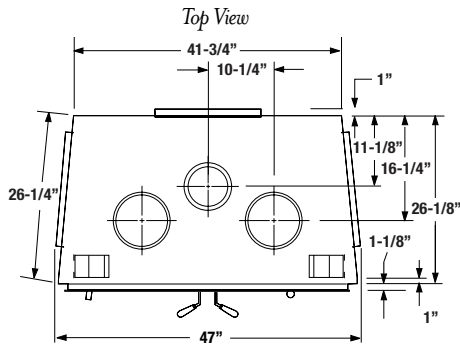
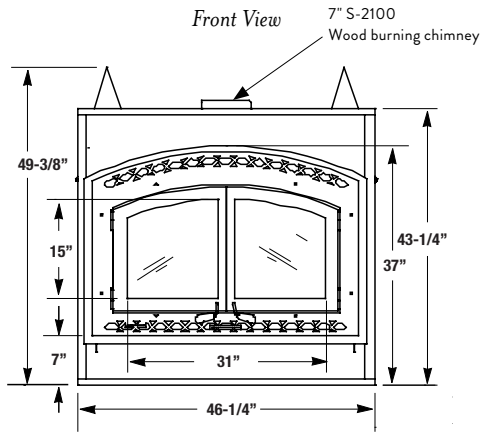

Left Side View

Right Side View

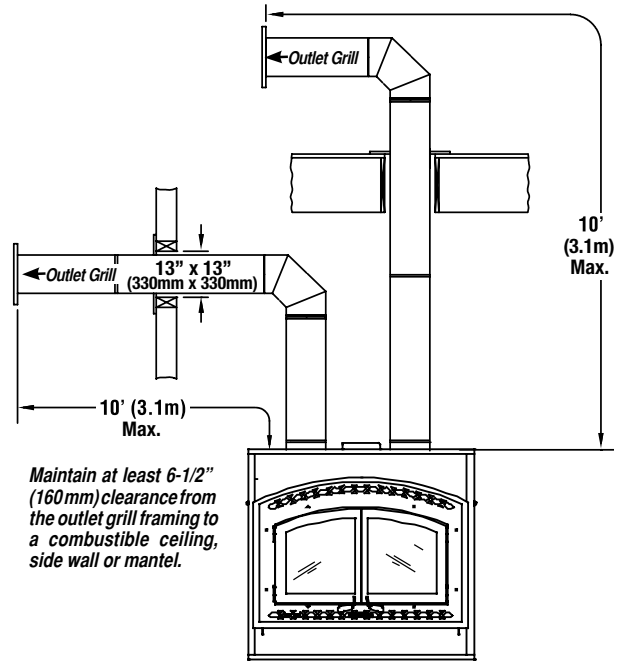
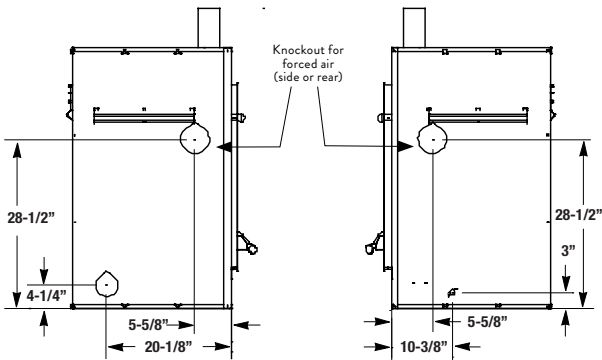

PRODUCT SPECIFICATIONS

Glass Viewing Area (W x H)	31" x 15"
Firebox Interior (W x H x D+)	31" x 14-1/2" x 14"
Interior Cubic Feet	4.0
Maximum Log Size	30"
Chimney Size	7"
EPA Rating	1.3 grams/hr
Max BTU's	80,000
Heating Capacity (up to)	2,500 sq. ft.
Thermal Efficiency	70%
Blower	200 CFM
Weight	520 lbs.

+Measured in front of doors

IMPORTANT NOTES:

As with any fireplace, this appliance is extremely hot during operation. Read and understand all operating instructions before using this appliance. For further information, consult your dealer.

Local conditions, such as elevation, wind, vent configuration and choice of fuel will affect overall appearance of the fire and heating performance. Performance can also vary with home design and insulation, climate, condition and type of fuel used, appliance location, burn rate, accessories chosen, chimney installation and how the appliance is operated.

Diagrams, illustrations and photographs are not to scale—consult installation instructions. Product designs, materials, dimensions, specifications, colors and prices are subject to change or discontinuance without notice.