

VRT3500 SERIES

VENT-FREE GAS FIREBOXES

Superior
FIREPLACES®



STANDARD FEATURES

- 🔥 Available in 36" and 42" radiant smooth-faced model
- 🔥 Tall 28" opening accepts up to 30" vent-free gas logs
- 🔥 White stacked refractory panels (sides, back and hearth with ash lip)
- 🔥 Optional heat deflection hood (not required)
- 🔥 Includes mesh fire screens
- 🔥 Optional outside air kit
- 🔥 Optional blower
- 🔥 Durable textured powder coat finish
- 🔥 20 year limited warranty

*Compatible with any ANSI Z21.11.2 listed vent-free log set. Choose Superior vent-free log sets for best results.

LINER



White Stacked



White Herringbone

APPLIANCE SPECIFICATIONS

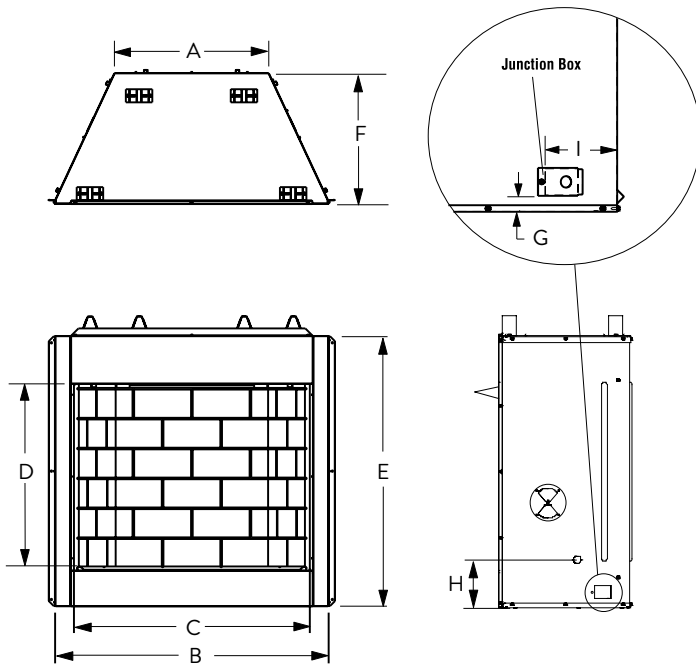

- Decorative twin pane screen door
- Blower kits
- Outside air kits
- Vent-free gas logs

FRAMING SPECIFICATIONS

	VRT3536	VRT3542
A	23-1/2"	29-1/2"
B	41-3/4"	47-3/4"
C	36"	42"
D	28"	28"
E	41-1/4"	41-1/4"
F	20"	20"
G	1-5/16"	1-5/16"
H	8-3/8"	8-3/8"
I	5-1/2"	5-1/2"

	VRT3536	VRT3542
A	42-1/4"	48-1/4"
B	44-1/4"	44-1/4"
C	20-1/2"	20-1/2"

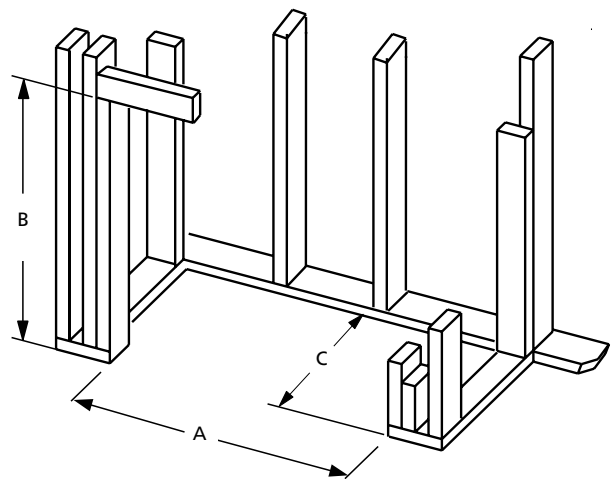

IMPORTANT NOTES:

As with any fireplace, this appliance is extremely hot during operation. Read and understand all operating instructions before using this appliance. For further information, consult your dealer.

Local conditions, such as elevation, wind, vent configuration and choice of fuel will affect overall appearance of the fire and heating performance. Performance can also vary with home design and insulation, climate, condition and type of fuel used, appliance location, burn rate, accessories chosen, chimney installation and how the appliance is operated.

Diagrams, illustrations and photographs are not to scale—consult installation instructions. Product designs, materials, dimensions, specifications, colors and prices are subject to change or discontinuance without notice.



© 2022 Innovative Hearth Products

785842M 03/22

Visit us online
SuperiorFireplaces.us.com

