

WCT4920 SERIES

HIGH EFFICIENCY WOOD BURNING FIREPLACES

Superior
FIREPLACES®



STANDARD FEATURES

- 🔥 Circulating design features facade, square or arch doors and ceramic glass for optimum heat transfer
- 🔥 EPA variable-rate certified high-efficiency wood heater
- 🔥 2.0 cubic foot insulated firebox that accepts up to 19" log size for increased performance
- 🔥 White smooth refractory panels with integrated ash lip and steel log retainer
- 🔥 Air combustion control for variable heat output with air boost for faster wood ignition during startup
- 🔥 Includes insulated outside air kit (required for use)
- 🔥 55,000 BTUs and heats up to 1,500 square feet*
- 🔥 Efficient air wash system that keeps glass clean
- 🔥 Steel doors available with heat resistant door handle that stays cool to the touch
- 🔥 Includes heat activated 200 CFM variable-speed blower for time-delayed heat distribution
- 🔥 HeatFlo™ air kit and/or thermostatically controlled forced air kit available (three maximum outlets)
- 🔥 Durable high temperature paint finish
- 🔥 20 Year Limited Warranty

DOORS (one required)



Smooth-Steel



Cast-Iron



Smooth-Steel

INTERIOR (standard)



White Smooth

FACADES (one required)



Louvered Arch



Louvered Square



Clean Face

APPLIANCE SPECIFICATIONS

FRAMING SPECIFICATIONS

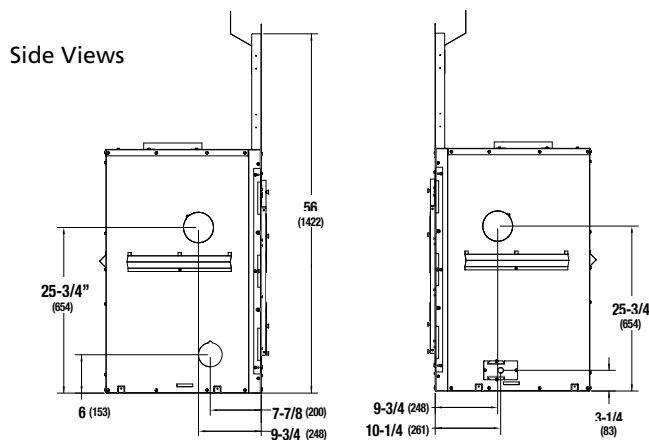
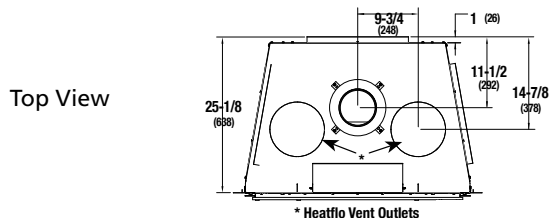
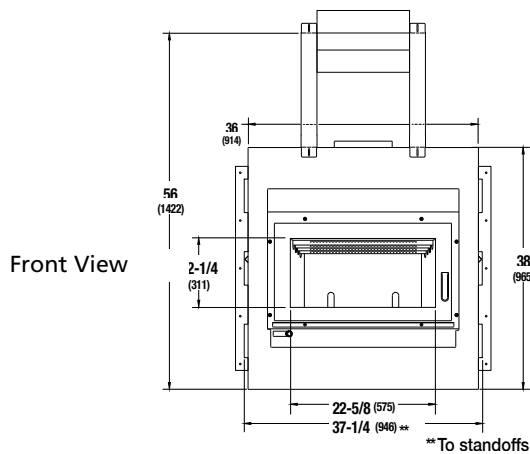

IMPORTANT NOTES:

As with any fireplace, this appliance is extremely hot during operation. Read and understand all operating instructions before using this appliance. For further information, consult your dealer.

Local conditions, such as elevation and choice of fuel will affect overall appearance of the fire and heating performance. Performance can also vary with home design and insulation, ceiling height, accessories chosen and appliance location.

Diagrams, illustrations and photographs are not to scale — consult installation instructions. Product designs, materials, dimensions, specifications, colors and prices are subject to change or discontinuance without notice.

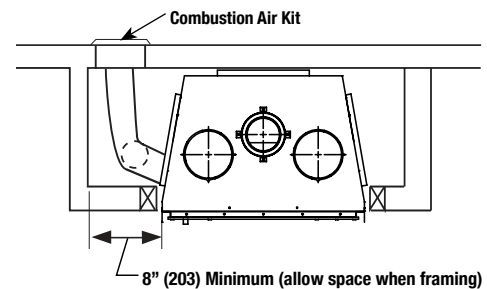
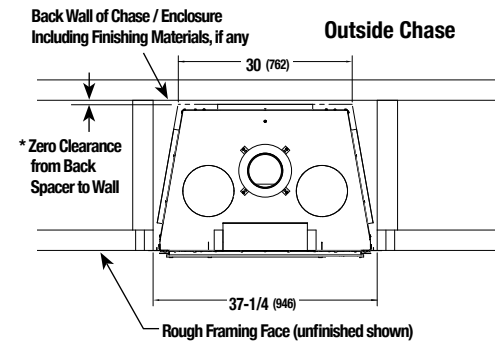
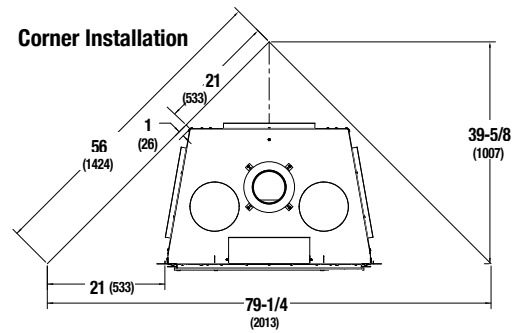

PRODUCT SPECIFICATIONS

Glass Viewing Area (W x H)	22-1/2" x 12-1/4"
Firebox Interior (W x H x D)	22" x 11-3/4" x 12"
Interior Cubic Feet	2.0
Maximum Log Size	19"
Chimney Size	6"
EPA Rating	1.9 grams/hr
Max BTUs	55,000
Heating Capacity (up to)	1,500 sq. ft.
Thermal Efficiency	72%
Blower	250 CFM
Weight	330 lbs.



© 2022 Innovative Hearth Products

785854M 03/22

Visit us online
SuperiorFireplaces.us.com



Report # 14-199 R1