

WCT6940 SERIES

HIGH EFFICIENCY WOOD BURNING FIREPLACES

Superior
FIREPLACES®



STANDARD FEATURES

- 🔥 Circulating design features facade, arch doors and ceramic glass for optimum heat transfer
- 🔥 EPA variable-rate certified and Washington State approved high-efficiency wood heater
- 🔥 Spacious 4.0 cubic foot insulated firebox that accepts up to 30" log size for increased performance
- 🔥 Steel double doors with heat resistant door handles that stay cool to the touch
- 🔥 Stacked textured refractory panels with integrated ash lip and decorative cast iron log retainer
- 🔥 Catalytic combustor for maximum performance
- 🔥 Bypass control: Greater airflow during startup for faster wood ignition and no smoke spillage when reloading
- 🔥 Includes insulated outside air kit (required for use)
- 🔥 80,000 BTUs and heats up to 2,500 square feet*
- 🔥 Efficient air wash system that keeps glass clean
- 🔥 Includes heat activated 200 CFM variable-speed blower for time-delayed heat distribution
- 🔥 Durable high temperature paint finish
- 🔥 20 Year Limited Warranty

INTERIOR (standard)



Textured Stacked
Panels

DOORS (one required)



Smooth-Steel



Smooth-Steel

superiorfireplaces.us.com

APPLIANCE SPECIFICATIONS

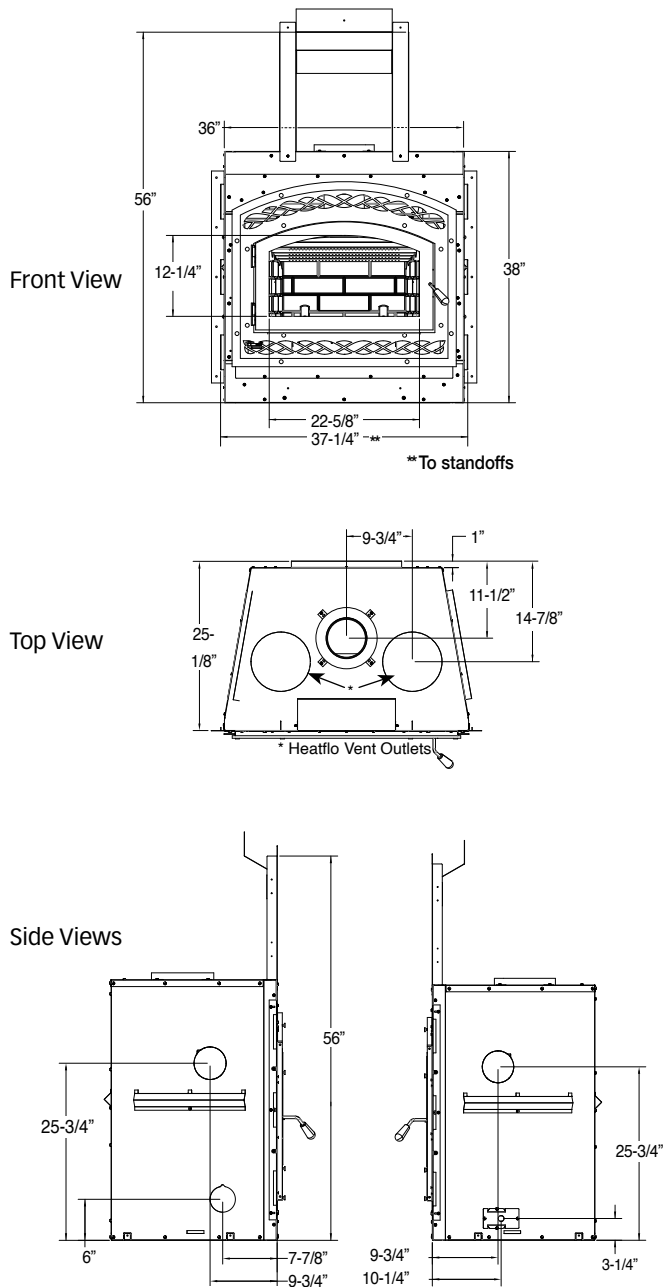

IMPORTANT NOTES:

As with any fireplace, this appliance is extremely hot during operation. Read and understand all operating instructions before using this appliance. For further information, consult your dealer.

Local conditions, such as elevation and choice of fuel will affect overall appearance of the fire and heating performance. Performance can also vary with home design and insulation, ceiling height, accessories chosen and appliance location.

Diagrams, illustrations and photographs are not to scale — consult installation instructions. Product designs, materials, dimensions, specifications, colors and prices are subject to change or discontinuance without notice.



© 2023 Innovative Hearth Products

785856M 09/23

FRAMING SPECIFICATIONS

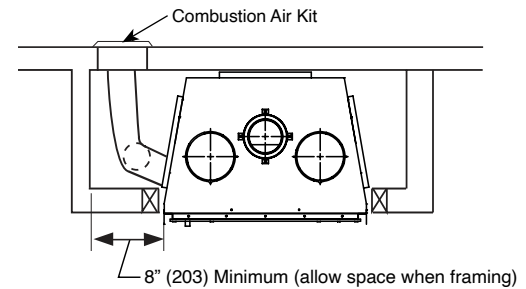
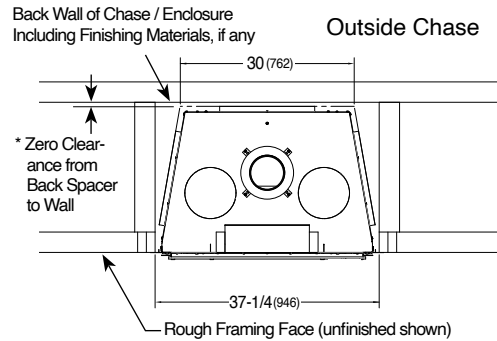
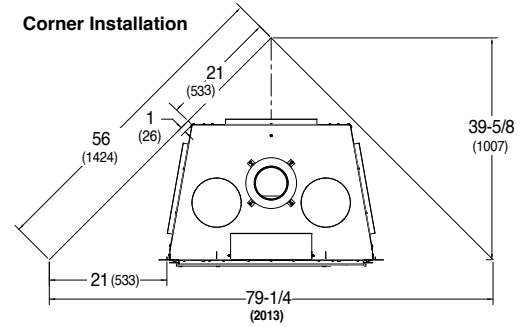

PRODUCT SPECIFICATIONS

Glass Viewing Area (W x H)	22-1/2" x 12-1/4"
Firebox Interior (W x H x D)	22" x 11-3/4" x 12"
Interior Cubic Feet	2.0
Maximum Log Size	19"
Chimney Size	6"
EPA Rating	1.9 grams/hr
Max BTUs	55,000
Heating Capacity (up to)	1,500 sq. ft.
Thermal Efficiency	72%
Blower	200 CFM
Weight	330 lbs.

Visit us online
SuperiorFireplaces.us.com



Report # 14-199 R1