

DRT3500 SERIES

DIRECT VENT GAS FIREPLACES

Superior
FIREPLACES®



STANDARD FEATURES

- Available in 35", 40" and 45" models
- Mid-size 17" depth saves installed floor space
- Combination top/rear flue configuration
- Electronic ignition with seamless battery backup and provides continued operation in the event of a power outage (IPI/CPI switch standard)
- Outstanding heating efficiency for increased comfort and lower operating costs
- Ceramic glass for optimum heat transfer and a protective screen*
- Beautifully crafted high-definition log set
- Face selections include a Vista inside fit façade or one of several Designer overlap fit façades (required)
- Interior selections consist of black porcelain and a variety of ceramic fiber liners (required)
- Mood enhancing interior illumination with six distinctive settings
- Factory installed blower with six speed settings to fine tune your heating needs
- Full-function remote control included (IPI/CPI, thermostat, flame height, blower, lighting)
- Durable textured powder coat finish
- 20 year limited warranty

*All applicable models comply with ANSI Z21.50/88 barrier requirements.

superiorfireplaces.us.com

FAÇADES (ONE REQUIRED)



VISTA — Black



REFLECTION — Black or Warm Chestnut (shown)



CRAFTSMAN — Black (shown) or Warm Chestnut

REMOTE (INCLUDED)



ProFlame II Remote

LINERS

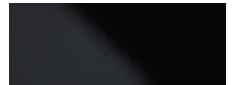

Porcelain Liner Kit (Black)



Blackstone



Greystone



Blended Brown

STAINLESS SURROUNDS (OPTIONAL)



Available as four-sided or three-sided (Vista Façade req.).

SPECIFICATIONS

APPLIANCE DIMENSIONS

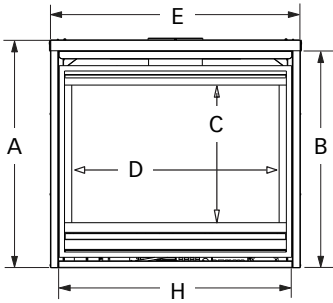

Front View

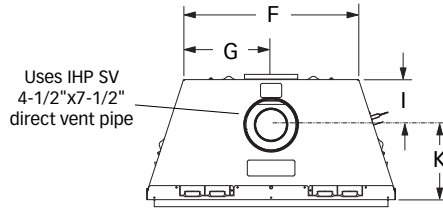

Top View

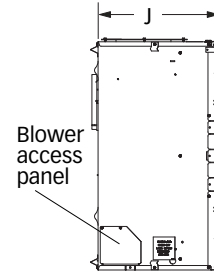

Left Side View

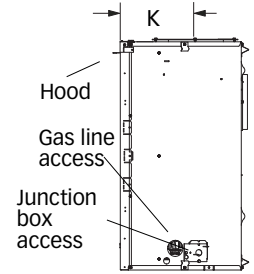

Right Side View

MODEL	A	B	C	D	E	F	G	H	I	J	K
35" MODELS	32-1/8"	30-1/2"	19-1/2"	29-1/4"	35-1/4"	25"	12-1/2"	32-7/8"	6-7/8"	17"	10-1/8"
40" MODELS	37-1/8"	35-1/2"	24-1/2"	34-1/4"	40-1/4"	30"	15"	37-7/8"	6-7/8"	17"	10-1/8"
45" MODELS	37-1/8"	35-1/2"	24-1/2"	39-1/4"	45-1/4"	35"	17-1/2"	42-7/8"	6-7/8"	17"	10-1/8"

FRAMING DIMENSIONS

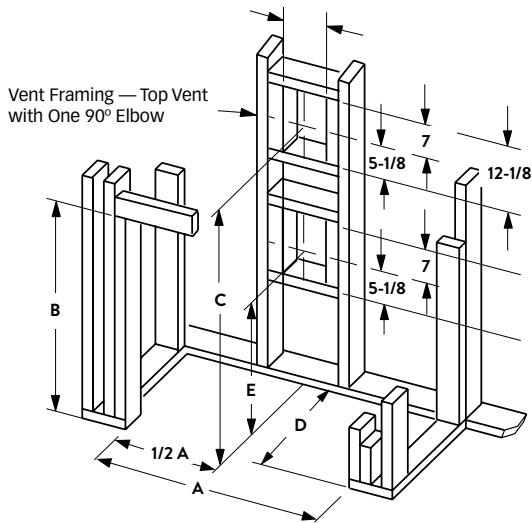

MODEL	A	B	C	D	E
35" MODELS	35-7/8"	36-1/4" *	38-3/4"	18-1/2"	23-3/8"
40" MODELS	40-7/8"	41-1/4" *	43-3/4"	18-1/2"	28-1/4"
45" MODELS	45-7/8"	41-1/4" *	43-3/4"	18-1/2"	28-1/4"

* Includes 4" for fold-up standoffs

FIREPLACE EFFICIENCIES

MODEL	FUEL	BTU/HR	P4 / ENERGY*
DRT3535	NG	26,000	62.5%
DRT3535	LP	23,000	69.6%
DRT3540	NG	33,000	62.4%
DRT3540	LP	27,000	62.6%
DRT3545	NG	35,000	62.9%
DRT3545	LP	30,000	63.0%

*Intermittent ignition systems.

IMPORTANT NOTES:

As with any fireplace, this appliance is extremely hot during operation. Read and understand all operating instructions before using this appliance. For further information, consult your dealer.

Local conditions, such as elevation, wind, vent configuration and choice of fuel will affect overall appearance of the fire and heating performance. Performance can also vary with home design and insulation, climate, condition and type of fuel used, appliance location, burn rate, accessories chosen, chimney installation and how the appliance is operated.

Diagrams, illustrations and photographs are not to scale—consult installation instructions. Product designs, materials, dimensions, specifications, colors and prices are subject to change or discontinuance without notice.

On the Cover: DRT3540 shown with Blackstone Ceramic Fiber Liner

